

Data Sheet

H1 Axial Piston Pump

045/053 cm³ Single Pump

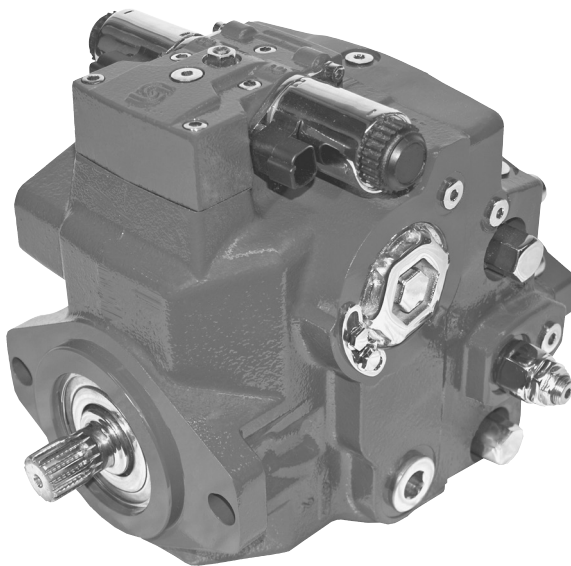

Introduction

For more than 40 years, Danfoss has been developing state-of-the-art components and systems for mobile machinery used in off-highway operations around the world. We have become a preferred supplier by offering the best of what really matters: The hardware inside your vehicle application.

H1 - our new generation of servo-controlled hydrostatic pumps - is no exception.

The H1 range is built around an advanced electrical control and available in a wide range of displacements. It is designed for quality and reliability and offers expanded functionality, greater total efficiency, and easy installation.

All H1 control and sensor options are PLUS+1 Compliant.

PLUS+1[®] allows you to rapidly develop and customize electronic machine control. It opens up the future by combining machine controls and diagnostics in an integrated operating network.

Features

- Designed for quality and reliability
 - One design concept
 - Single piece swash plate
- Installation and packaging benefits
 - Length optimized pump
 - Minimum one clean side
 - Higher corner power
 - Higher package size ratio
 - Standardized connector interface
 - Expanded functionality through PLUS+1[®]
- Optimized for electrical control
 - Electro-hydraulic control options include Electrical Displacement Control (EDC), Forward-Neutral-Reverse (FNR) and Non-Feedback Proportional Electric (NFPE)
 - Automotive Control (AC)
 - Fan Drive Control (FDC)
 - Common control across entire family
- Expanded functionality
 - PLUS+1 Compliant control and sensor options
 - Active, high response pressure limiter available
- Greater total efficiency
 - Minimized control losses
 - Improved charge circuit
 - Lower control pressure for less power consumption

Technical Specifications

Physical properties

Features	Unit	Sizes	
		045	053
Displacement	cm ³ [in ³]	45 [2.75]	53.8 [3.28]
Weight (without PTO and filter)	kg [lb]	41 [90]	

Operating parameters

Input speed	Minimum	min-1 (rpm)	500	
	Rated		3400	
	Maximum		3500	
System pressure	Maximum working pressure*	bar [psi]	420 [6090]	380 [5510]
	Maximum pressure		450 [6525]	400 [5800]
	Minimum low loop		10 [150]	
Case pressure	Rated	bar [psi]	3.0 [40]	
	Maximum		5.0 [75]	

* Applied pressures above maximum working pressure requires Danfoss application approval.

T301 069E

Schematic

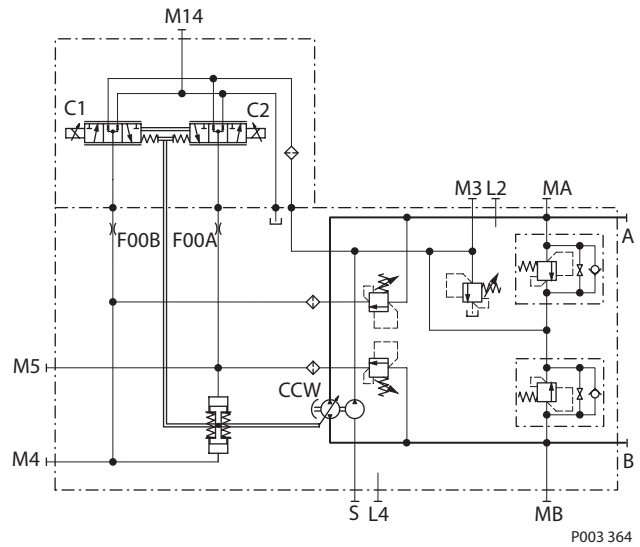

Dimensions

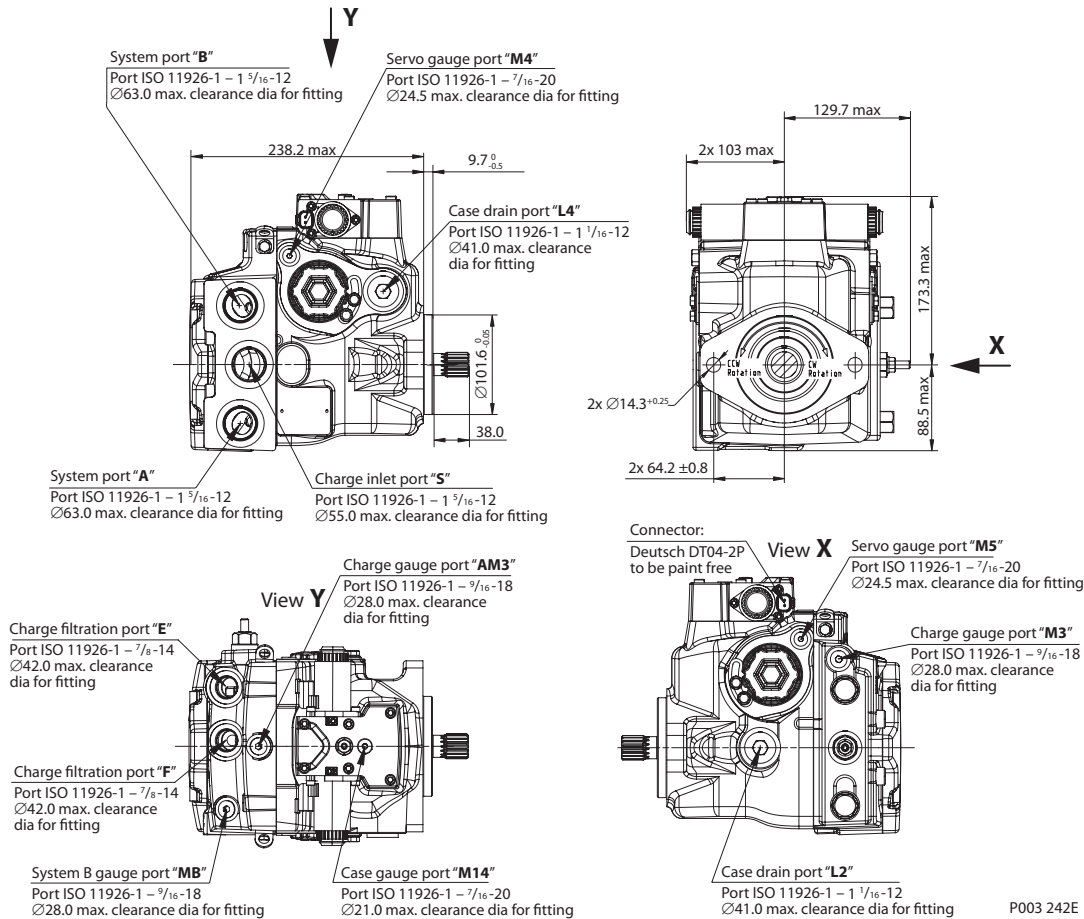

Danfoss Power Solutions US Company
2800 East 13th Street
Ames, IA 50010, USA
Phone: +1 515 239 6000

Danfoss Power Solutions GmbH & Co. OHG
Krokamp 35
D-24539 Neumünster, Germany
Phone: +49 4321 871 0

Danfoss Power Solutions ApS
Nordborgvej 81
DK-6430 Nordborg, Denmark
Phone: +45 7488 2222

Danfoss Power Solutions
22F, Block C, Yishan Rd
Shanghai 200233, China
Phone: +86 21 3418 5200

Danfoss can accept no responsibility for possible errors in catalogues, brochures and other printed material. Danfoss reserves the right to alter its products without notice. This also applies to products already on order provided that such alterations can be made without consequential changes being necessary in specifications already agreed. All trademarks in this material are property of the respective companies. Danfoss and the Danfoss logotype are trademarks of Danfoss A/S. All rights reserved.