



**PARALLEL AXIS REDUCTION UNITS
FOR SINGLE-SCREW EXTRUDER**

TABLE OF CONTENTS

	page
GENERAL	4
DESIGNATION, LEGEND, YIELDS	5
HEAT OUTPUT	6
CHOOSING THE REDUCTION UNIT	7
 NOMINAL POWERS	
PBE SERIES	8
PCE SERIES	9
 TWISTING MOMENTS	
PBE SERIES	10
PCE SERIES	10
 DIMENSIONS	
PBE SERIES	11
PCE SERIES	12
 VERSION	 13
CONSTRUCTIVE SHAPE	13
PBE – PCE EXACT RATIOS	14
GEARED MOTOR UNITS	15
RADIAL LOADS, WEIGHTS AND QUANTITY OF OIL..	16
LUBRICATION	17

GENERAL

The new series of parallel axis reduction units has been studied and designed specifically for use on systems for the **SINGLE-SCREW EXTRUSION** of various materials such as plastic, rubber, etc.

Our range includes two-stage reduction units, **PBE series**, with a nominal reduction ratio ranging between 6.3 and 28, and three-stage reduction units, **PCE series**, with a nominal ratio ranging between 8 and 125.

By being able to have the same reduction ratios 8÷28 on both series either solution can be chosen for the same application, depending on the dimensions and version required.

As a matter of fact, with the three-stage series, thanks to the bigger centre distance, the reduction unit can be mounted with the high-speed shaft and flange for connecting the extrusion screw on the same side, in the so-called characteristic “U” shape.

HOUSING

For all sizes, the housings of the reduction units are made in G25 grey cast iron, suitably dimensioned for heavy duty work; they are suitable for mounting horizontally or vertically.

OUTPUT

The output flange, housing the thrust bearing and used for mounting the extrusion screw, is integrated in the housing cast. Featuring cast insets for improved lubrication of the thrust bearing. The thrust bearing mounted on the slow-speed shaft is the 294_E type and dimensioned for heavy duty working conditions. In the standard version, screw keying is done with a feather key but it may also be done with a grooved profile, according to the most common standards in force; do not hesitate to contact our Technical Office for different requirements.

GEARS

The helicoidal profile gears are made in case hardened, tempered, straightened steel, designed for fatigue resistance (**25.000 hours** with $f_m=1$) according to the ISO 6336 and DIN 3990 standards and verified on the basis of the AGMA 2001 standard.

LUBRICATION AND COOLING

Lubrication of gears and bearings is normally by splashing or in an oil bath. For some mounting positions we recommend using a forced lubrication system for the thrust bearing, with an interlocked pump or motor pump.

In those cases where the reduction unit's heat output is insufficient in relation to the mechanical power it absorbs, an external water-oil cooling system can be used and may also be exploited for the forced lubrication of the thrust bearing.

DESIGNATION

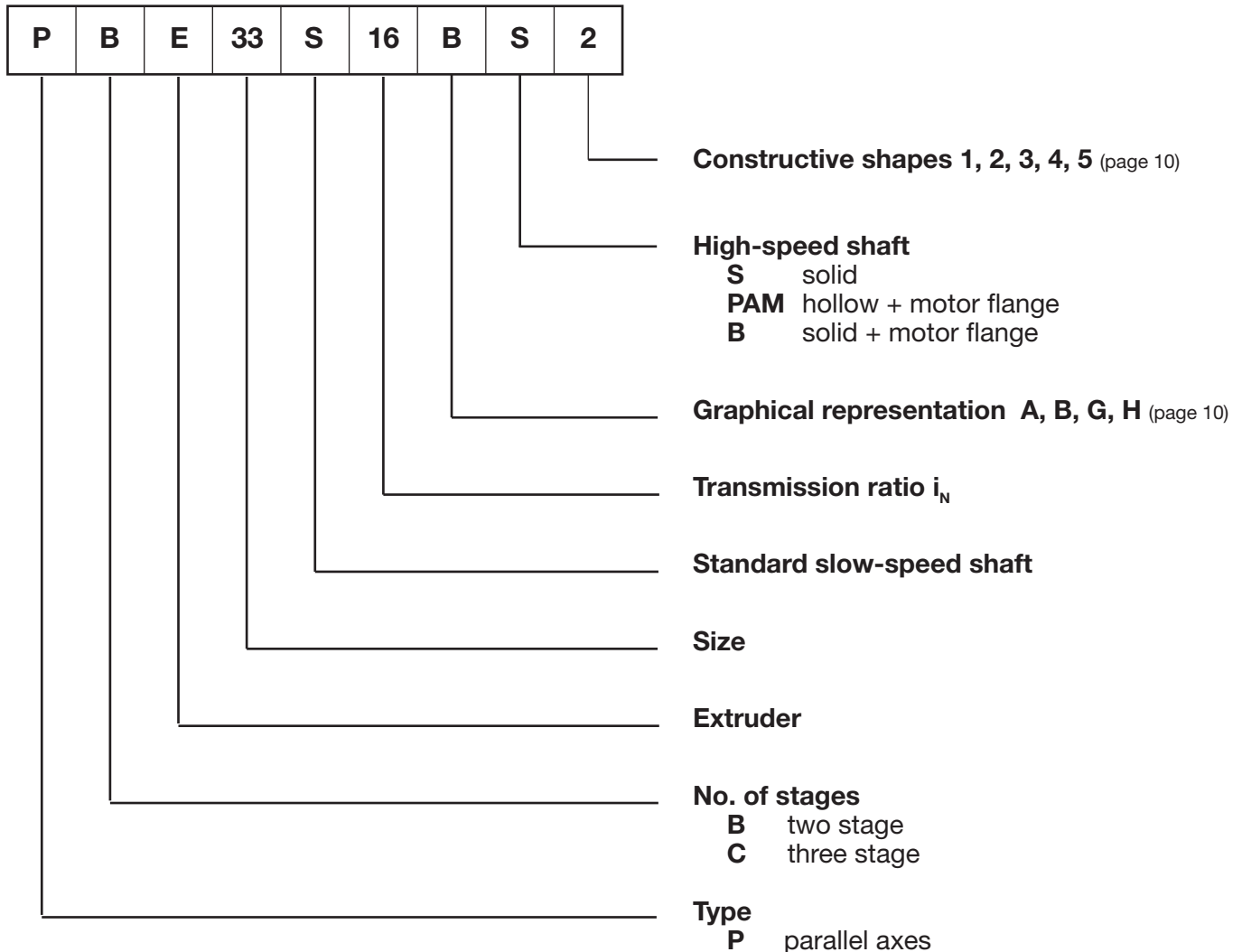

LEGEND

f_m	Service factor	
i	Transmission ratio	
i_N	Nominal transmission ratio	
η	Yield	
f_a	Environmental heat factor	
n_1	Angular speed of the high-speed shaft	min ⁻¹ or rpm
n_2	Angular speed of the slow-speed shaft	min ⁻¹ or rpm
P_t	Heat output	kW
P_{tN}	Nominal heat output	kW
P_N	Nominal power	kW
P	Absorbed power	kW
t	Temperature	°C celsius
T	Twisting moment	Nm
T_N	Nominal twisting moment	Nm
Fr_1	Radial load of the high-speed shaft	N
Fr_2	Radial load of the slow-speed shaft	N
J_1	Moment of inertia of the high-speed shaft	Kgm ²

YIELDS (η)

96% Two-stage parallel
94% Three-stage parallel

HEAT OUTPUT

The heat output values relative to natural cooling with an environmental temperature of 20°C are given in the following table.

Heat output (kW)

i_N	03	13	23	33	43	53	63	73	83	93	103
PBE	30	38	50	65	81	101	125	155	190	230	290
PCE	21	29	38	50	63	83	103	130	167	206	252

For different environmental temperatures, the value of the nominal heat output has to be multiplied by the environmental heat factor, given in the following table.

$$P_{tN} = P_t \times f_a$$

Environmental heat factor f_a

Environmental temperature	Natural cooling
10 °C	1,14
20 °C	1,00
30 °C	0,86
40 °C	0,72
50 °C	0,56

When a lot of heat has to be dissipated it will be necessary to use a cooling unit with motor pump and heat exchanger. Such a system uses the oil inside the reduction unit, making it circulate inside a bundle water-oil heat exchanger so it can be cooled.

For the size of this type of system it is necessary to know:

- the quantity of heat to be dissipated [kcal];
- the temperature of the inlet water [°C];
- the water flow rate [l/min];
- the oil flow rate from the pump [l/min];
- the size of the exchanger;
- the environmental temperature [°C].

We suggest contacting our Technical Office to ensure the cooling unit is dimensioned correctly.

CHOOSING THE REDUCTION UNIT

Data required:

- power of the motor used P (kW)
- input speed n_1 (min^{-1})
- transmission ratio i_N
- application f_m

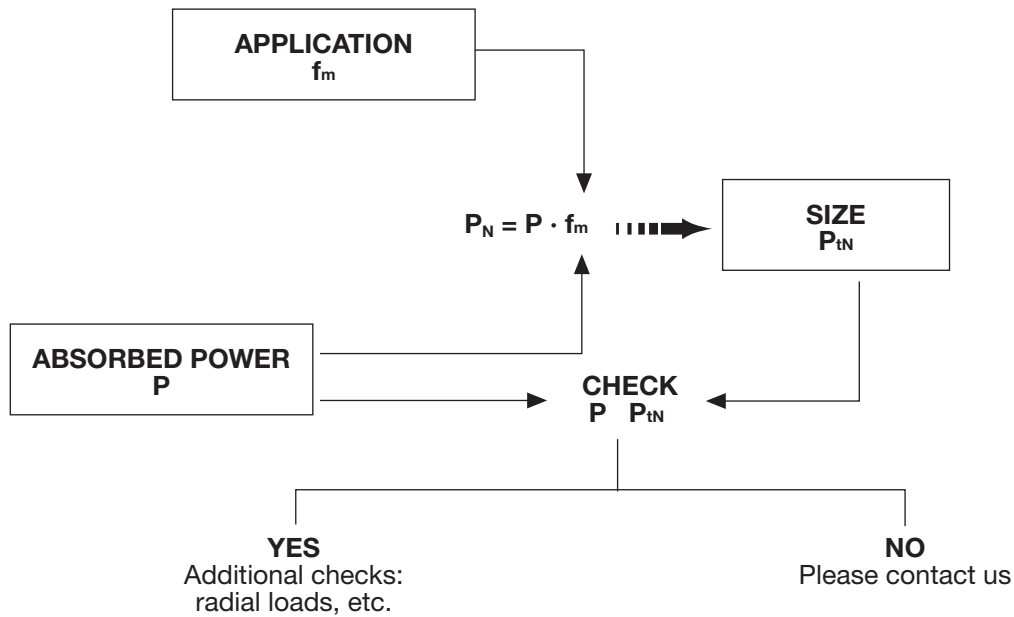

Example:

- $i_N = 20$
- $P = 120 \text{ kW}$ at 1500 min^{-1}
- environ. temperature = 30°C
- $f_m = 1,75$

$$P_N = P \cdot f_m = 120 \times 1,75 = 210 \text{ kW}$$

The PCE 63 reduction unit supplies 230 kW at 1500 min^{-1} and would be mechanically suitable for the application. The nominal heat output with natural cooling would be:

$$P_{tN} = 103 \times 0,86 = 88,6 \text{ kW}$$

As this value is less than power $P = 120 \text{ kW}$, the reduction unit should be provided with artificial cooling, to calculate according to the environmental conditions of where it is to be installed.

PBE Series - Nominal Powers (kW)

i _N	n ₁ n ₂ min ⁻¹		Size										
			03	13	23	33	43	53	63	73	83	93	103
6.3	1500	238	78	114	163	231	315	450	612	906	1323	1919	2631
	1000	159	52	76	109	154	210	300	408	604	88	1279	1754
	750	119	39	57	81	115	157	225	306	453	661	959	1315
7.1	1500	211	70	102	141	209	284	404	552	817	1135	1726	2369
	1000	141	46	68	94	139	189	269	368	545	756	1151	1579
	750	106	35	51	70	104	142	202	276	408	567	863	1184
8	1500	188	63	91	126	186	256	362	493	735	1021	1549	2124
	1000	125	42	61	84	124	170	241	329	490	681	1032	1416
	750	94	31	45	63	93	128	181	246	367	510	774	1062
9	1500	167	56	82	114	167	229	323	441	658	915	1384	1899
	1000	111	37	55	76	111	153	215	294	392	610	923	1266
	750	83	28	41	57	83	114	161	220	294	457	692	949
10	1500	150	53	73	101	148	203	286	414	588	816	1233	1691
	1000	100	35	48	67	99	135	191	276	392	544	822	1127
	750	75	26	32	50	74	101	143	207	294	408	616	845
11.2	1500	134	47	65	95	130	179	252	367	520	769	1091	1496
	1000	89	31	43	63	87	119	168	245	347	513	727	997
	750	67	23	32	47	65	90	126	183	260	384	545	748
12.5	1500	120	41	57	85	115	158	237	323	457	679	958	1314
	1000	80	28	38	56	76	105	158	215	304	453	638	876
	750	60	21	28	42	57	79	118	161	228	339	479	657
14	1500	107	39	53	74	107	147	205	301	428	595	895	1227
	1000	71	26	35	49	71	98	137	200	285	397	597	818
	750	54	19	26	37	53	73	102	150	214	297	447	613
16	1500	94	33	46	68	93	127	191	260	370	555	774	1062
	1000	63	22	31	45	62	85	127	173	246	370	516	708
	750	47	16	23	34	46	63	95	130	185	277	387	531
18	1500	83	28	43	59	85	118	163	223	343	478	716	983
	1000	56	19	28	39	57	79	109	148	228	318	477	655
	750	42	14	21	29	42	59	81	111	171	239	358	491
20	1500	75	26	36	54	72	100	149	204	290	441	604	828
	1000	50	17	24	36	48	66	99	136	193	294	402	552
	750	38	13	18	27	36	50	74	102	145	220	302	414
22.5	1500	67	23	33	46	66	91	136	186	265	370	553	759
	1000	44	16	22	30	44	61	91	124	177	246	369	506
	750	33	12	16	23	33	45	68	93	132	185	276	379
25	1500	60	22	29	41	60	82	124	169	241	336	502	688
	1000	40	14	19	27	40	55	82	112	160	224	334	459
	750	30	11	14	20	30	41	62	84	120	168	251	344
28	1500	54	19	27	37	54	74	111	152	217	302	451	620
	1000	36	13	18	24	36	49	74	101	144	201	301	413
	750	27	9	13	18	27	37	55	76	108	151	225	310

PCE Series - Nominal Powers (kW)

i _n	n ₁ n ₂		Size										
	min ⁻¹		03	13	23	33	43	53	63	73	83	93	103
8	1500	211	61	85.5	125	167.5	228	335	529	658	928	1310	1816
	1000	141	41	57	83.5	112	152	223	352	439	619	874	1211
	750	106	31	43	62.5	84	114	167	264	329	464	656	908
9	1500	188	57	82.5	119.5	160	217	318	475	623	881	1241	1698
	1000	125	38	55	79.5	105.5	145	212	317	415	588	828	1132
	750	94	28.5	41	59.5	80	109	159	238	312	441	621	849
10	1500	167	53	75.5	112.5	149	203	298	427	586	827	1186	1601
	1000	111	35.5	50.5	75	99	135	199	285	391	552	791	1068
	750	83	26.5	38	56	74.5	102	149	213	293	414	593	801
11.2	1500	150	47.5	67.5	101	135	182	277	365	544	777	1104	1466
	1000	100	31.5	45	67	90	121	185	243	363	518	736	978
	750	75	23.5	34	50.5	67.5	91	139	183	272	389	552	733
12.5	1500	134	47.5	62	90.5	122.5	167	251	329	491	713	1035	1364
	1000	89	28	41.5	60	81.5	111	168	219	327	475	690	909
	750	67	21	31	45	61.5	84	126	165	245	357	518	682
14	1500	120	40	55	80.5	109.5	151	225	310	439	641	932	1235
	1000	80	26.5	37	54	73	100	150	207	293	428	622	823
	750	60	20	27.5	40.5	55	75	113	155	220	321	466	618
16	1500	107	34	49	69	98.5	134	191	264	391	540	791	1103
	1000	71	22.5	32.5	46	66	90	127	176	261	360	527	736
	750	54	17	24.5	34.5	49.5	67	96	132	196	270	396	552
18	1500	94	30	44	61	88.5	121	171	233	347	483	706	991
	1000	63	20	29.5	40.5	59	80.5	114	155	231	322	471	660
	750	47	15	22	30.5	44.5	60.5	86	116	174	242	353	496
20	1500	83	28	39.5	60.5	81.5	112.5	173	234	315	478	666	885
	1000	56	18.5	26	40.5	54.5	75	116	156	210	319	444	590
	750	42	14	20	30	40.5	56	87	117	158	239	333	443
22.5	1500	75	24	35	53	71	94.5	151	195	281	422	542	764
	1000	50	16	23.5	35	47.5	63.5	101	130	187	282	361	509
	750	38	12	17.5	26.5	35.5	47.5	76	98	141	211	271	382
25	1500	67	23	32.5	49	65.5	92	139	192	260	390	529	726
	1000	44	15.5	21.5	29	43.5	61.5	93	128	173	260	353	484
	750	33	11.5	16	22	33	46	70	96	130	195	265	363
28	1500	60	20.5	29	44	59	83	124.5	172	233	350	477	656
	1000	40	14	19.5	29	39.5	55.5	83	115	155	234	318	437
	750	30	10.5	14.5	22	29.5	41.5	62.5	86	117	175	238	328
31.5	1500	54	17.5	26	37	53	71.5	106	146	209	297	429	567
	1000	36	12	17.5	25	35.5	47.5	70.5	98	139	198	286	378
	750	27	9	13	18.5	26.5	35.5	53	73	105	149	215	284
35.5	1500	48	16	23.5	34	48.5	65	97	133	189	270	372	515
	1000	32	10.5	16	22.5	32.5	43.5	64.5	89	126	180	248	344
	750	24	8	12	17	24.5	32.5	48.5	66.5	95	135	286	258
40	1500	42	14.5	21	30	43.5	58.5	86.5	119	168	241	333	463
	1000	28	9.5	14	20	29	39	57.5	79	112	161	222	309
	750	21	7.2	10.5	15	22	29	43.5	59.5	84	121	167	232
45	1500	38	12.5	19	27	38.5	52.5	77	105	149	214	297	418
	1000	25	8.5	12.5	18	26	35	51.5	70	100	143	198	279
	750	19	6.5	9.5	13.5	19.5	26	38.5	50.5	75	107	149	209
50	1500	32	11.5	16.5	25.5	35	47.5	68.5	94.5	134	204	268	373
	1000	22	7.5	11	17	23.5	32	48.5	63	89	136	179	249
	750	17	5.6	8.3	13	17.5	24	34.5	47.5	67	102	134	187
56	1500	30	10.7	14.5	22.5	30.5	42.5	64.5	88.5	117	179	237	334
	1000	20	7.1	9.7	15	20.5	28	43	59	78	120	158	223
	750	15	5.4	7.3	11	15.5	21	32.5	44.5	59	90	118	167
63	1500	27	9.4	13.5	19.5	27	37.5	56.5	77.5	110	156	208	297
	1000	18	6.3	9.1	13	18	25	37.5	51.5	73	104	139	198
	750	13	4.7	6.8	10	35.5	18.5	28.5	39	55	78	104	149
71	1500	24	8.3	11.7	17	25	32.5	49	67.5	94.5	135	194	262
	1000	16	5.5	7.8	13.5	17	21.5	38.5	45	63	90	129	174
	750	12	4.1	5.9	8.5	12.5	16.5	24.5	33.5	47.5	68	97	131
80	1500	21	7.7	10	15.5	21.5	34.5	42.5	62.5	80.5	125	168	244
	1000	14	5.1	6.7	10.5	14.5	20.5	28.5	41.5	53.5	83	112	163
	750	11	3.8	5	8	11	15	21	31.5	40.5	63	84	122
90	1500	19	6.6	9.2	13	18.5	26	39	53.5	74	106	155	211
	1000	13	4.4	6.1	9	12.5	17.5	26	35.5	49.5	71	104	141
	750	9.4	3.3	4.6	6.5	9.3	13	19.5	26.5	37	53	78	106
100	1500	17	6.1	8.4	12.1	17	24	35.8	49	67.5	97	131	196
	1000	11	4.1	5.6	8.1	11.4	16	23.8	32.5	45	65	88	131
	750	8.3	3	4.2	6.1	8.5	12	17.9	24.5	34	49	66	98
112	1500	15	5.6	7.6	11	15.6	20.5	32.7	44.5	61.5	88	120	165
	1000	10	3.7	5.1	7.3	10.4	13.5	21.8	30	41	59	80	110
	750	7.5	2.8	3.8	5.5	7.8	10	16.3	22.5	30.5	44	60	83
125	1500	13	4.6	6.2	8.9	13.1	17.1	27	33	49.5	72	101	151
	1000	8.9	3	4.1	5.9	8.7	11.4	18	22	33	48	68	101
	750	6.7	2.3	3.1	4.5	6.6	8.6	13.5	16.5	25	36	50	76
140	1500	12	4.1	5.5	8	11.8	15.5	24.5	29.5	44.5	64	91	137
	1000	8	2.7	3.7	5.3	7.9	10.3	16.3	19.5	29.5	43	61	91
	750	6	2	2.8	4	5.9	7.7	12.1	14.5	22.5	32	46	68

PBE Series - Twisting moments T_{n2} (Nm)

i_n	Size										
	03	13	23	33	43	53	63	73	83	93	103
6.3	3100	4400	6200	8800	12000	17400	24200	34800	50100	73000	100100
7.1	3100	4400	6300	8900	12100	17500	24400	35000	50500	73400	100700
8	3150	4400	6300	8900	12200	17600	24500	35200	50800	73800	101200
9	3150	4450	6400	9000	12300	17700	24700	35400	51100	74200	101800
10	3200	4450	6400	9000	12300	17800	24700	35700	51400	74700	102500
11.2	3200	4500	6400	9000	12400	17900	24900	35900	51600	75200	103100
12.5	3250	4500	6500	9100	12500	18000	25100	36100	51900	75700	103800
14	3250	4550	6500	9100	12500	18100	25100	36300	52300	76000	104200
16	3250	4600	6500	9200	12600	18200	25300	36500	52500	76500	105000
18	3300	4600	6600	9200	12700	18400	25600	36700	52900	76800	105400
20	3300	4600	6600	9300	12800	18400	25700	37000	53100	77200	105900
22.5	3300	4650	6700	9400	12900	18500	25800	37200	53600	77900	106900
25	3350	4650	6700	9400	12900	18600	25900	37400	53900	78300	107400
28	3350	4700	6700	9500	13000	18700	26100	37600	54200	78700	108000

PCE Series - Twisting moments T_{n2} (Nm)

i_n	Size										
	03	13	23	33	43	53	63	73	83	93	103
8	2900	4100	6100	8300	10900	15900	24900	31600	43900	62800	87000
9	3000	4400	6300	8800	11500	16800	24900	33300	46400	66000	90000
10	3100	4500	6600	9100	11900	17500	24900	34900	48500	70000	94000
11.2	3250	4500	6600	9200	12500	18100	25100	36200	50800	72500	101000
12.5	3250	4600	6600	9300	12700	18300	25300	36500	52100	75700	104000
14	3250	4600	6600	9300	12800	18300	25300	36700	52500	76000	105000
16	3300	4600	6700	9400	12800	18500	25700	36800	52800	76800	105000
18	3300	4700	6700	9500	12900	18700	25700	37000	53600	77400	106000
20	3300	4800	7100	9900	13600	20200	27600	38400	56600	77700	107000
22.5	3350	4700	7000	9800	13400	20000	27100	37900	55900	76600	108000
25	3350	4850	7200	10050	13700	20400	28100	39000	57500	78800	108000
28	3350	4850	7200	10050	13700	20400	28100	39000	57500	78800	108000
31.5	3400	4850	7200	10050	13700	20400	28100	39000	57500	78800	109000
35.5	3400	4950	7350	10250	13900	20800	28500	39500	58500	80300	110000
40	3450	4950	7350	10250	13900	20800	28500	39500	58500	80300	110000
45	3450	4950	7350	10250	13900	20800	28500	39500	58500	80300	111000
50	3450	5000	7450	10400	14200	21000	28900	40200	59300	81400	111000
56	3500	5000	7450	10400	14200	21000	28900	40200	59300	81400	112000
63	3500	5000	7450	10400	14200	21000	28900	40200	59300	81400	113000
71	3550	5000	7450	10400	14200	21000	28900	40200	59300	81400	114000
80	3550	5000	7450	10400	14200	21000	28900	40200	59300	81400	114000
90	3600	5000	7450	10400	14200	21000	28900	40200	59300	81400	114500
100	3600	5000	7450	10400	14200	21000	28900	40200	59300	81400	115000
112	3600	5000	7450	10400	14200	21000	28900	40200	59300	81400	116200
125	3600	4500	6700	9650	13200	19100	26000	36100	53600	75400	116200
140	3600	4500	6700	9650	13200	19100	26000	36100	53600	75400	116200

PBE Series two stage – Dimensions

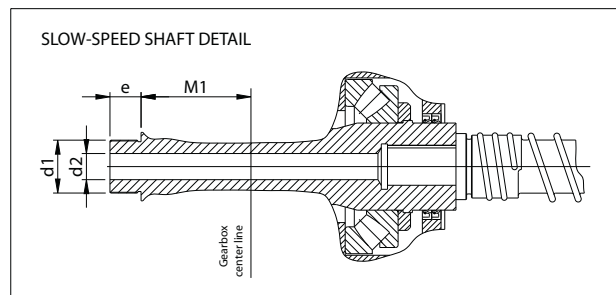
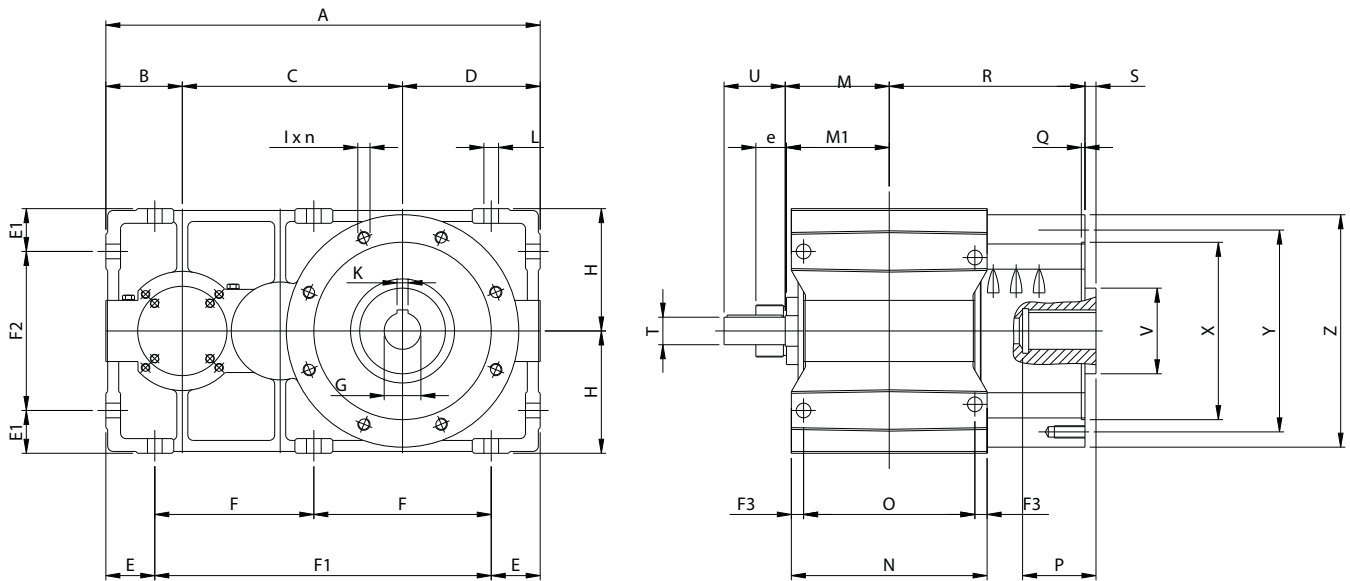

Size	A	B	C	D	d1	d2	E	E1	e	F	F1	F2	F3	G	H	I	n
03	455	80	225	140	M50	24	50	45	30		345	160	12	32	125	M12	8
13	502	90	252	160	M50	27	56	48	30		390	184	15	38	140	M12	8
23	565	100	285	180	M65	29	63	50	40		439	220	15,5	42	160	M16	8
33	632	112	320	200	M65	34	70	60	40		492	240	18	48	180	M20	8
43	710	125	360	225	M85	42	80	70	50		550	260	20	60	200	M20	8
53	795	140	405	250	M85	55	90	80	50		615	290	22,5	70	225	M20	12
63	890	160	450	280	M85	55	100	90	50	345		320	26	80	250	M24	12
73	1000	180	505	315	M90	60	112	100	50	388		360	30	90	280	M24	12
83	1125	200	570	355	M90	60	125	112	50	437,5		406	35	100	315	M24	12
93	1265	225	643	400	M120	80	140	125	50	492,5		460	40	110	355	M30	12
103	1420	250	720	450	M120	80	160	140	50	550		520	45	125	400	M33	12

Size	K	L	M	M1	N	O	P	Q	R	S	T	U	V	X	Y	Z	Bearing
03	10	16	114	113	204	180	80	5	205	8	28	63	80	180	205	230	29415E
13	10	18	125	124	230	200	80	5	230	8	32	70	90	200	230	260	29417E
23	12	20	142	140	256	225	80	6	260	17	35	80	110	230	260	300	29420E
33	14	22	158	157	286	250	110	6	290	17	40	90	130	260	300	350	29424E
43	18	24	176	175	320	280	110	6	320	18	45	100	140	290	330	380	29428E
53	20	27	192	188	360	315	140	6	355	18	50	112	160	310	350	400	29430E
63	22	30	216	212	407	355	140	8	405	20	55	125	170	365	400	450	29434E
73	25	33	242	240	460	400	140	8	445	20	60	140	180	400	450	500	29436E
83	28	36	273	270	520	450	140	8	490	20	70	160	190	450	500	600	29440E
93	28	39	302	302	580	500	180	10	560	24	80	180	200	520	600	680	29452E
103	32	42	340	340	650	560	180	10	640	24	90	200	220	600	680	750	29456E

PCE Series three stage – Dimensions

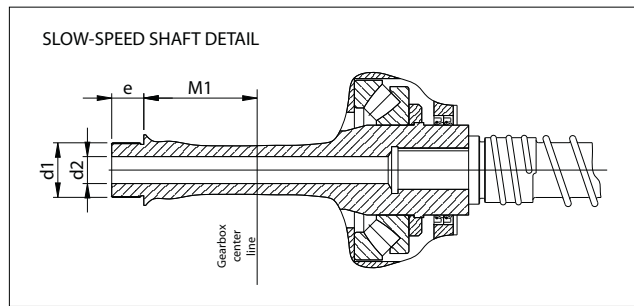
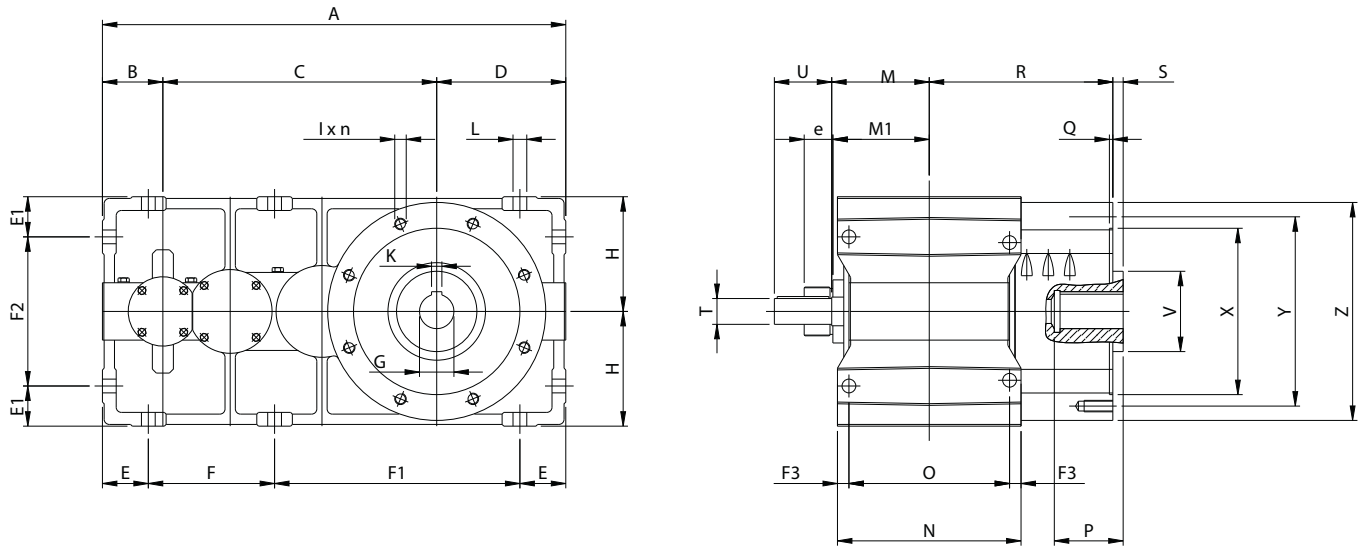

Size	A	B	C	D	d1	d2	E	E1	e	F	F1	F2	F3	G	H	I	n
03	508	63	305	140	M50	24	50	45	30	136	272	160	17	32	125	M12	8
13	572	70	342	160	M50	27	56,5	48	30	153	306	184	18	38	140	M12	8
23	645	80	385	180	M65	29	63	50	40	173	346	220	20,5	42	160	M16	8
33	722	90	432	200	M65	34	70	60	40	194	388	240	23	48	180	M20	8
43	810	100	485	225	M85	42	81	70	50	216	432	260	25	60	200	M20	8
53	907	112	545	250	M85	55	90,5	80	50	242	484	290	22,5	70	225	M20	12
63	1015	125	610	280	M85	55	101	90	50	271	542	320	26	80	250	M24	12
73	1140	140	685	315	M90	60	112,5	100	50	305	610	360	30	90	280	M24	12
83	1285	160	770	355	M90	60	125	112	50	345	690	406	35	100	315	M24	12
93	1445	180	865	400	M12	80	140,5	125	50	388	776	460	40	110	355	M30	12
103	1620	200	970	450	M12	80	160,5	140	50	433	866	520	45	125	400	M33	12

Size	K	L	M	M1	N	O	P	Q	R	S	T	U	V	X	Y	Z	Bearing
03	10	16	114	113	214	180	80	5	205	8	24	56	80	180	205	230	29415E
13	10	18	125	124	236	200	80	5	230	8	28	63	90	200	230	260	29417E
23	12	20	142	140	266	225	80	6	260	17	32	70	110	230	260	300	29420E
33	14	22	158	157	296	250	110	5	290	17	35	80	130	260	300	350	29424E
43	18	24	176	175	330	280	110	6	320	18	40	90	140	290	330	380	29428E
53	20	27	192	188	360	315	140	6	355	18	45	100	160	310	350	400	29430E
63	22	30	216	212	407	355	140	8	405	20	50	112	170	365	400	450	29434E
73	25	33	242	240	460	400	140	8	445	20	55	125	180	400	450	500	29436E
83	28	36	273	270	520	450	140	8	490	20	60	140	190	450	500	600	29440E
93	28	39	302	302	580	500	180	10	560	24	70	160	200	520	600	680	29452E
103	32	42	340	340	650	560	180	10	640	24	80	180	220	600	680	750	29456E

VERSION

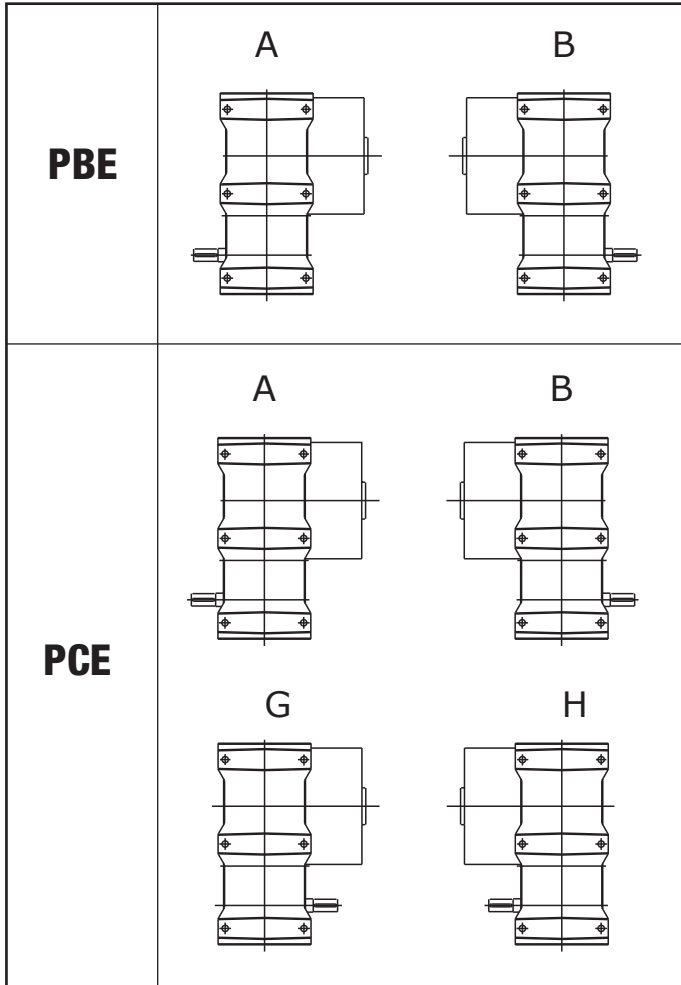

CONSTRUCTIVE SHAPE

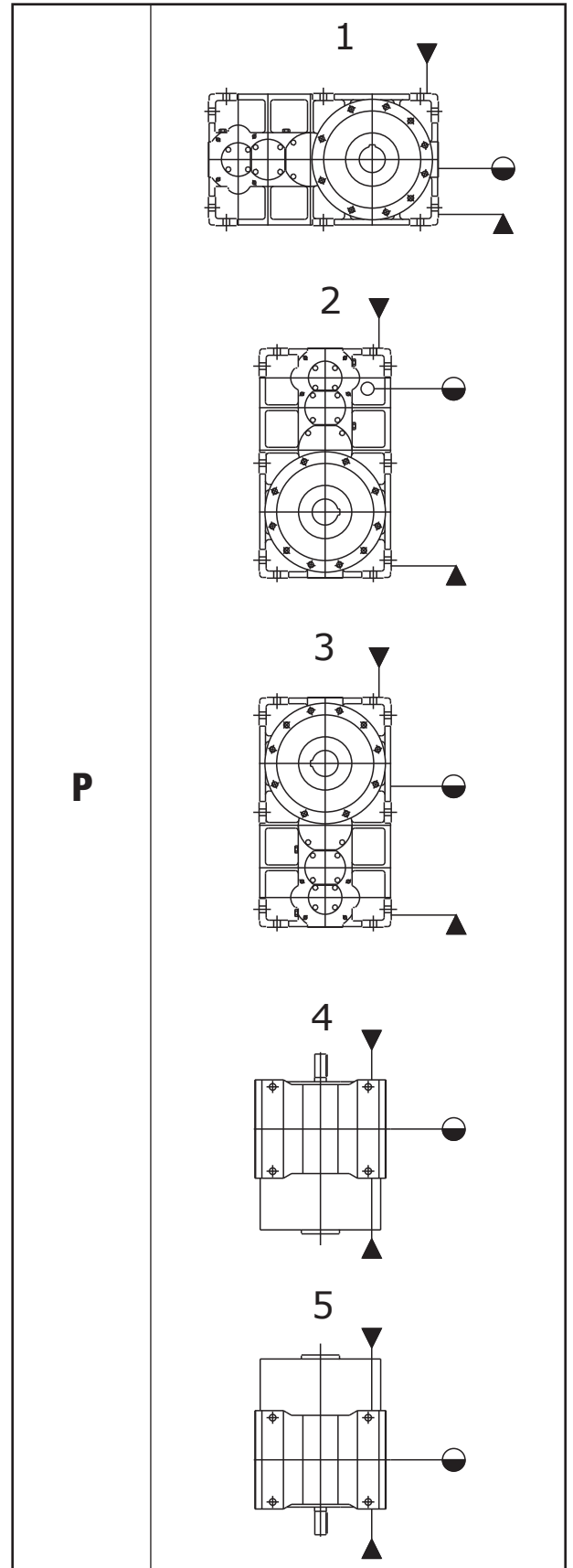

▼ Filling up plug

● Level plug

▲ Draining plug

PBE Series - Exact ratios

i _n	Size										
	03	13	23	33	43	53	63	73	83	93	103
6.3	6,462	6,278	6,192	6,223	6,223	6,321	6,462	6,278	6,192	6,223	6,223
7.1	7,231	7,003	7,279	6,955	6,955	7,074	7,231	7,003	7,279	6,955	6,955
8	8,118	7,835	8,137	7,795	7,795	7,942	8,118	7,835	8,137	7,795	7,795
9	9,154	8,8	9,132	8,769	8,769	8,955	9,154	8,8	9,132	8,769	8,769
10	9,739	9,933	10,301	9,913	9,913	10,153	9,739	9,933	10,301	9,913	9,913
11.2	11,077	11,282	10,965	11,275	11,275	11,589	11,077	11,282	10,965	11,275	11,275
12.5	12,696	12,915	12,492	12,923	12,923	12,421	12,696	12,915	12,492	12,923	12,923
14	13,641	13,868	14,359	13,885	13,885	14,378	13,641	13,868	14,359	13,885	13,885
16	15,885	16,13	15,457	16,168	16,168	15,54	15,885	16,13	15,457	16,168	16,168
18	18,769	17,487	18,092	17,538	17,538	18,362	18,769	17,487	18,092	17,538	17,538
20	20,544	20,828	19,692	20,911	20,911	20,099	20,544	20,828	19,692	20,911	20,911
22.5	22,615	22,917	23,692	23,019	23,019	22,125	22,615	22,917	23,692	23,019	23,019
25	25,063	25,385	26,238	25,51	25,51	24,519	25,063	25,385	26,238	25,51	25,51
28	28	28,346	29,292	28,5	28,5	27,393	28	28,346	29,292	28,5	28,5

PCE Series - Exact ratios

i _n	Size										
	03	13	23	33	43	53	63	73	83	93	103
8	7,865	8,021	8,137	8,263	7,995	7,942	7,865	8,021	7,9	8	7,995
9	8,752	8,928	8,815	9,181	8,848	8,825	8,752	8,928	8,791	8,877	8,848
10	9,747	9,949	9,812	10,208	9,799	9,811	9,747	9,949	9,79	9,858	9,799
11.2	11,487	11,105	10,934	11,362	11,499	10,921	11,487	11,105	10,918	10,962	11,499
12.5	12,855	12,428	12,205	12,67	12,732	12,178	12,855	12,428	12,202	12,212	12,732
14	13,614	13,953	13,658	14,166	14,198	13,615	13,614	13,953	13,675	13,614	14,198
16	16,274	15,733	16,274	15,891	15,89	16,202	16,274	15,733	16,346	16,213	15,89
18	18,449	17,837	18,396	17,904	17,863	18,302	18,449	17,837	18,531	18,301	17,863
20	19,692	20,361	19,602	20,283	20,196	19,495	19,692	20,361	19,78	19,487	20,196
22.5	23,227	22,564	22,121	23,019	23,609	22,125	23,227	22,564	22,121	23,625	23,609
25	24,5	25,117	24,615	25,577	24,837	24,583	24,5	25,117	24,615	24,886	24,837
28	27,271	27,988	27,413	28,436	27,495	27,331	27,271	27,988	27,413	27,623	27,495
31.5	32,099	31,243	32,308	31,651	32,087	32,117	32,099	31,243	32,308	30,692	32,087
35.5	35,873	34,962	36,154	35,296	35,643	35,858	35,873	34,962	36,154	36,063	35,643
40	40,205	39,254	40,592	39,462	39,688	40,153	40,205	39,254	40,592	40,284	39,688
45	45,231	44,26	45,769	44,268	44,333	45,135	45,231	44,26	45,769	45,153	44,333
50	51,13	50,178	48,696	49,875	49,722	50,984	51,13	50,178	48,696	50,834	49,722
56	54,483	57,278	55,385	56,502	56,047	54,307	54,483	57,278	55,385	57,548	56,047
63	62,192	61,389	63,482	64,454	63,577	61,95	62,192	61,389	63,482	65,605	63,577
71	71,615	71,062	73,484	69,058	72,692	71,292	71,615	71,062	73,484	70,269	72,692
80	77,158	83,314	79,423	79,89	78,01	82,969	77,158	83,314	79,423	81,244	78,01
90	90,462	90,752	93,846	93,612	90,638	89,975	90,462	90,752	93,846	87,761	90,638
100	98,538	99,335	102,722	101,942	98,215	97,982	98,538	99,335	102,722	103,587	98,215
112	107,858	109,349	113,077	111,555	116,867	107,221	107,858	109,349	113,077	113,325	116,867
125	131,58	121,183	125,315	122,769	128,524	118	131,58	121,183	125,315	124,688	128,524
140	147	135,385	140	136,023	142,301	130,739	147	135,385	140	138,115	142,301

GEARED MOTOR UNITS

PBE-PCE parallel reduction units

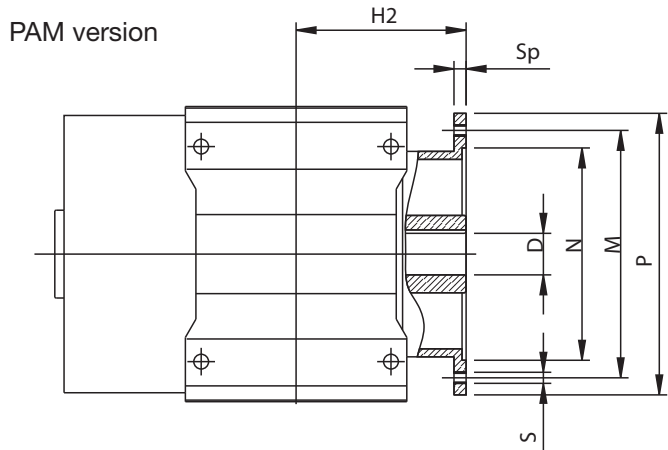
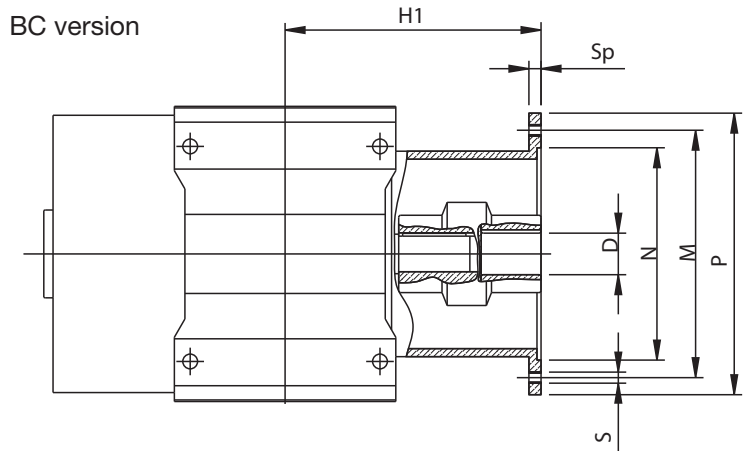
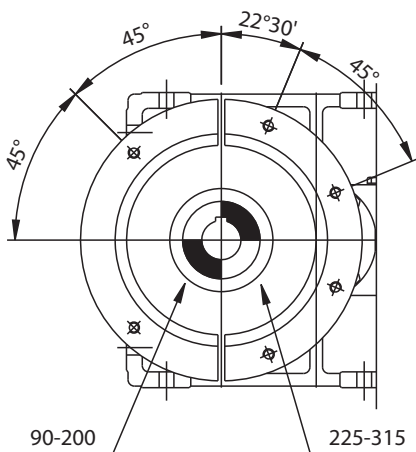
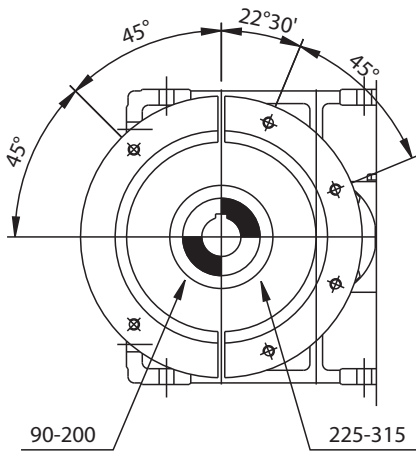

Reduction Unit size	IEC Motor	D H7	M	N	P	S	Sp	PBE		PCE	
								H1	H2	H1	H2
13	132	38	265	230	300	M12	16	279	185	272	185
	160	42	300	250	350	M16	18	309	190	302	
	180	48	300	250	350	M16	18	309		302	
23	132	38	265	230	300	M12	16			296	198
	160	42	300	250	350	M16	18	336	203	326	203
	180	48	300	250	350	M16	18	336	203	326	
	200	55	350	300	400	M16	20	336			
33	160	42	300	250	350	M16	18			352	218
	180	48	300	250	350	M16	18	362	218	352	218
	200	55	350	300	400	M16	20	362	228		
43	160	42	300	250	350	M16	18			380	
	180	48	300	250	350	M16	18			380	235
	200	55	350	300	400	M16	20	390	240	380	240
53	200	55	350	300	400	M16	20	418	260	406	260
	225	60	400	350	450	M16	20			436	280
63	225	60	400	350	450	M16	20	485		472	304
	250	65	500	450	550	M16	20		324	472	
73	225	60	400	350	450	M16	20		330		
	250	65	500	450	550	M16	20	526		511	350
	280	75	500	450	550	M16	20	526		511	
83	250	65	500	450	550	M16	20			557	
	280	75	500	450	550	M16	20	577	400	557	400
	315	80	600	550	660	M20	24	607	420	587	
93	315	80	600	550	660	M20	24	656	450	636	450

All values refer to IEC standardised motors.

RADIAL LOADS (daN)

When the reduction unit has to be motorised by means of a transmission that generates radial loads at the end of the high-speed shaft it is necessary to ensure they do not exceed the maximum permitted values listed in the following table.

n_1	03	13	23	33	43	53	63	73	83	93	103
1500	340	430	460	570	700	770	835	1270	1580	2020	2700
1000	360	480	520	600	750	820	920	1390	1830	2230	3120
750	395	520	580	670	820	870	1060	1540	2020	2540	3310

Use the following formulas to find the radial load.

Positive drive belt	V-belt
$F_{r1} = \frac{3000 \cdot P_1}{d \cdot n_1}$	$F_{r1} = \frac{5000 \cdot P_1}{d \cdot n_1}$

Where:

F_{r1} = radial force on the reduction unit's high-speed shaft (daNm);

P_1 = inlet power to the reduction unit (kW);

n_1 = the reduction unit's inlet shaft rotation speed (rev/min);

d = pitch diameter of the pulley installed on the high-speed shaft (m).

WEIGHTS (kg)

	03	13	23	33	43	53	63	73	83	93	103
PBE	115	158	219	325	470	600	800	1200	1740	2600	3700
PCE	125	164	255	340	493	670	930	1360	1930	2860	4120

QUANTITY OF OIL (l)

All reduction units are normally supplied without oil. The approximate quantities for a horizontal mounting are given in the following table. For mounting positions different from "1", fill up to the level indicated by the level plug or level rod.

Do not fill above the level to avoid possible leaks and overheating.

	03	13	23	33	43	53	63	73	83	93	103
PBE	5	6.5	9	13	18	23	33	44	55	78	108
PCE	5.5	7.5	10	16	22	28	36	48	62	87	120

LUBRICATION

ISO and AGMA viscosity degree

Speed n ₂ (min ⁻¹)	Standards	Environmental temperature (°C)		
		from -10 to -15	from 0 to +30	from +10 to +50
Less than 100	ISO - AGMA	VG 68 2 EP	VG 150 4 EP	VG 220 5 EP
More than 100	ISO - AGMA	VG 100 3 EP	VG 220 5 EP	VG 320 6 EP

Mineral oils

Viscosity ISO at 40°C	BP Energol	ESSO Spartan	MOBIL Mobilgear	SHELL Omala	TEXACO Meropa	TOTAL Carter	AGIP Blasia
VG 320	GR-XP 320	EP 320	632	320	320	EP 320	320
VG 220	GR-XP 220	EP 220	630	220	220	EP 220	220
VG 150	GR-XP 150	EP 150	629	150	150	EP 150	150
VG 100	GR-XP 100	EP 100	627	100	100	EP 100	100
VG 68	GR-XP 68	EP 68	626	68	68	EP 68	68

Recommended synthetic oils

Viscosity ISO at 40°C	BP Energol	CASTROL Tribol	MOBIL SHC	KLUEBER EG4
VG 320	EPX 320	1510/320	632	320
VG 220	EPX 220	1510/220	630	220
VG 150	HTX 150	1510/150	629	150
VG 68			626	

Mineral oils: max. operating temperature 90°C

Synthetic oils: max. operating temperature 100°C (110°C for short periods of time).

Do not mix different brands of synthetic oils.

Oil change frequency (h)

TYPE	Oil temperature		
	65°C	80°C	90°C
Mineral	8000	4000	2000
Synthetic	20000	15000	10000



REGGIANA RIDUTTORI s.r.l.

Via Martiri di Marzabotto, 7 - 42020 S. Polo d'Enza (RE) Italy
Tel. +39 0522 259111 • Fax +39 0522 874321
e-mail: info@reggianariduttori.com • www.reggianariduttori.com