



PLUS+1™ GUIDE Graphical User Integrated Development Environment

Take Control of Your Applications with GUIDE!

GUIDE (Graphical User Integrated Development Environment) is a member of the PLUS+1 family of products that provide complete vehicle control solutions. Other PLUS+1 products include controllers, displays, and electrohydraulic products.

GUIDE allows graphical development of machine management applications, downloading of software via CAN, and development of user specific service and diagnostic tools. GUIDE maximizes OEM engineering productivity and protects intellectual property

GUIDE Development Tool

GUIDE uses graphic symbols and components to create application drawings that are easily understood by inexperienced programmers. The drawing represents the software application which is then automatically coded and serves as the documentation for the program.

Local Address:

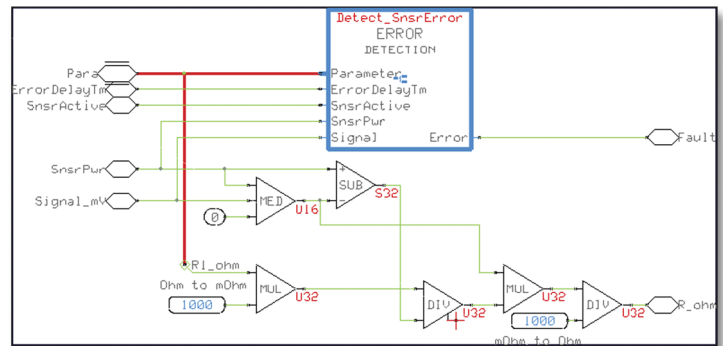
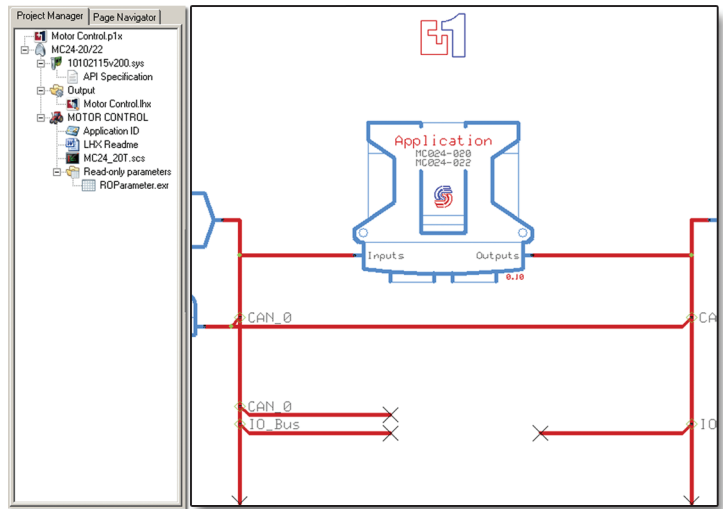

GUIDE Screens



GUIDE Features

- Rapid production of applications enabled by dragging and dropping proven graphical software objects
- Built on reliable, robust field-proven tools
- Assures protection of proprietary intellectual property
- Graphical editor allows easy development of applications by inexperienced programmers
- Service tool has multiple access protection levels to protect against unauthorized use and tampering
- PLUS+1 compliant function blocks increase productivity by allowing rapid set-up of Sauer-Danfoss compliant sensor, pump, motor, and valve products

GUIDE Development Tool

- Symbols and components are selected from a palette and dropped onto the drawing space.
- Sauer-Danfoss developed function blocks are available for common control requirements such as PID control, ramp, filter, and command signal profiles.
- GUIDE compliance blocks allow rapid integration of input and output signals from Sauer-Danfoss electrohydraulic products through the use of predetermined signal types and parameter default settings.
- Graphical programming reduces the number of steps required to develop an application; source code is generated directly from the application drawing to reduce coding errors.
- On-line and context-sensitive help allows easy comprehension of product features.
- Application data logging aids machine diagnostics.

Downloader

GUIDE includes an easy to use download tool. Application files are downloaded to the target controller via CAN. The download tool allows PLUS+1 users to access all of the controllers and intelligent devices on the PLUS+1 network. Simple, fast, reliable communications between a controller, or network of controllers, and a PC USB port is accomplished with the CG150 CAN/USB gateway.

Service Tool

GUIDE includes a Service Tool that provides the ability to monitor and tune the operation of all devices on a PLUS+1 network. The application developer can use basic Service Tool building blocks to develop a custom look and feel Service Tool. Standard features of the Service Tool include bar graph displays, oscilloscope displays for trending and tuning, and data export to spreadsheet tools. User-defined graphics allow the Service Tool to have a proprietary look and feel.

The Service Tool allows:

- OEM customization of the Service Tool look and feel.
- Importation of user-defined graphics in JPEG, TIFF, GIF, or BMP format.
- Access to any device on PLUS+1 network via CAN, using the CG150 CAN/USB gateway.
- Data logging.
- Read and write access to tuning parameters.
- Protection for determining the level of access to PLUS+1 device data.
- Viewing of history logs maintained in the PLUS+1 device.

PLUS+1 GUIDE Minimum System Requirements

Operating system
Microsoft® Windows® XP (32-bit) or Windows 7 (32/64-bit)
MSXML 4.0 Service Pack 2 (Microsoft XML Core Services)
Microsoft .Net Framework 4
Local administrative privileges on PC running PLUS+1 GUIDE
Hardware
1.5 GHz processor
1 GB of system memory
595 MB of available hard disk space
1024 x 768 or higher resolution graphics card/monitor with 16 bit color
Other
Access to e-mail for license registration
Adobe Acrobat Reader v7.0 or higher

Related Product

Description	Sauer-Danfoss part number
CG150 CAN/USB gateway	10104136
RG150 CAN/USB gateway	See <i>Reference Literature</i> table

PLUS+1 Service Tool Minimum System Requirements

Operating system
Microsoft® Windows® XP (32-bit) or Windows 7 (32/64-bit)
MSXML 4.0 Service Pack 2 (Microsoft XML Core Services)
Local administrative privileges on PC running PLUS+1 Service Tool
Hardware
1.0 GHz processor
1 GB of system memory
125 MB of available hard disk space
1024 x 768 or higher resolution graphics card/monitor with 16 bit color
Other
Adobe Acrobat Reader v7.0 or higher

Reference Literature

Sauer-Danfoss product literature on line at: www.sauer-danfoss.com	Order number
PLUS+1 GUIDE Software User Manual	10100824
PLUS+1 RC 150 Remote Connectivity System Data Sheet	L1015290
PLUS+1 RG 150 Remote Connectivity Gateway Data Sheet	L1022999