

---

**POMPE AD INGRANAGGI SERIE MUST**  
***GEARS PUMPS SERIES MUST***  
**ZAHNRADPUMPEN BAUREIHE MUST**

**GM013**  
*must*

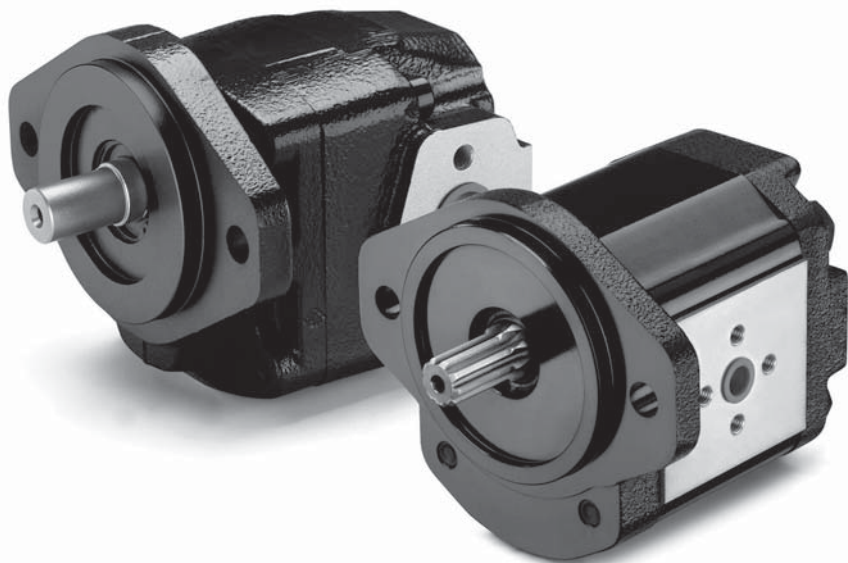

**INDICE**  
**INDEX**  
**INHALTSVERZEICHNIS**

ISTRUZIONI GENERALI DI IMPIEGO OPERATING INSTRUCTIONS ALLGEMEINE GEBRAUCHSANWEISUNGEN			3
INTRODUZIONE INTRODUCTION EINLEITUNG			4
PROGRAMMA DI PRODUZIONE PRODUCTION RANGE LIEFERPROGRAMM	<i>must</i>		8
<b>HPZ..2</b> POMPE AD INGRANAGGI GEAR PUMPS ZAHNRADPUMPEN	<i>must</i>		10
<b>HPZ..</b> POMPE MULTIPLE MULTIPLE GEAR PUMPS MEHRFACHPUMPEN	<i>must</i>		18
<b>HPX..2</b> POMPE AD INGRANAGGI GEAR PUMPS ZAHNRADPUMPEN	<i>must</i>		24
<b>HPX..</b> POMPE MULTIPLE MULTIPLE GEAR PUMPS MEHRFACHPUMPEN	<i>must</i>		30



#### CARATTERISTICHE FUNZIONALI

Le curve caratteristiche rappresentate nel presente catalogo sono tipiche di prodotti di produzione calcolati e testati in laboratorio e non necessariamente rappresentative di ogni unità.

#### CONSERVAZIONE A MAGAZZINO

I componenti idraulici vanno conservati nel loro imballaggio in luogo asciutto, lontano dall'irraggiamento solare o da sorgenti di calore o di ozono, in un ambiente con temperatura compresa tra -20°C e +50°C.

#### FLUIDO IDRAULICO

Si raccomanda di utilizzare fluidi idraulici definiti dalla norma ISO 6743-4.

#### TEMPERATURE LIMITE DI FUNZIONAMENTO

Temperatura minima -20°C.  
Temperatura massima continua +85°C.  
Temperatura massima di picco +100°C.  
L'esercizio con fluido a temperatura superiore a +85°C comporta un precoce decadimento delle caratteristiche funzionali delle guarnizioni impiegate. (NBR).

#### VISCOSITÀ

Deve essere verificata la rispondenza alla viscosità del fluido, richiesta per il corretto funzionamento: minima 10 mm<sup>2</sup>/s (per brevi periodi), massima 1000 mm<sup>2</sup>/s (per brevi periodi alla partenza), viscosità raccomandata 15-90 mm<sup>2</sup>/s.

#### PRESSIONE DI FUNZIONAMENTO IN ASPIRAZIONE

Pressione massima assoluta:  
P min 0,8 bar - P max 2 bar.

#### PRESSIONE DI DRENAGGIO

Pressione massima assoluta: 2 bar.

#### GRADO DI FILTRAZIONE

La classe di contaminazione consigliata per pompe e servocomandi è la seguente:  
Classe ISO4406 20/18/15 (NAS1638 - 9)

#### INSTALLAZIONE

Prima di far funzionare i componenti idraulici, assicurarsi che tutto il circuito idraulico sia accuratamente riempito d'olio e disareato. Filtrare l'olio di riempimento in modo da garantire la classe ISO o NAS richiesta. Prevedere nel circuito un sistema di filtraggio che garantisca la classe ISO o NAS richiesta. Avviare l'impianto lentamente a vuoto, facendolo spurgare bene dell'aria residua prima di applicare il carico. Sostituire i filtri dopo le prime 50 ore di lavoro. Sostituire il filtro del circuito idraulico ogni 500 ore di funzionamento. Sostituire il fluido idraulico come da specifiche del fornitore. In caso di mancato funzionamento dei componenti idraulici non insistere inutilmente; ricontrollare la corretta esecuzione dell'impianto ed eventualmente contattare il servizio tecnico.

#### FUNCTIONAL FEATURES

The characteristic curves represented in this catalogue are typical of laboratory calculated and tested production products and do not necessarily represent each unit.

#### WAREHOUSE STORAGE

The hydraulic components must be kept in their packaging in a dry place, away from sunlight or sources of heat or ozone, at a temperature between -20°C e +50°C

#### HYDRAULIC FLUID

We recommend using hydraulic fluids defined by the standard ISO 6743-4

#### OPERATING LIMIT TEMPERATURES

Minimum temperature -20°C  
Maximum continuous temperature +85°C  
Maximum peak temperature +100°C  
Operating with fluid at temperatures higher than +85°C entails early wear of the functional features of the gaskets used. (NBR)

#### VISCOSITY

The correspondence of the fluid to the viscosity required for correct operation must be checked:  
minimum 10 mm<sup>2</sup>/s (for short periods),  
maximum 1000 mm<sup>2</sup>/s (for short periods when starting), recommended viscosity 15-90 mm<sup>2</sup>/s.

#### INTAKE OPERATING PRESSURE

Maximum absolute value:  
P min 0.8 bar - P max 2 bar

#### DRAIN PRESSURE

Maximum absolute pressure: 2 bar

#### FILTRING DEGREE

The recommended contamination class for pumps and servocontrols is the following:  
Class ISO4406 20/18/15 (NAS1638 - 9)

#### INSTALLATION

Before operating the hydraulic components, make sure that the entire hydraulic circuit is completely filled with oil and deaerated. Filter the filling oil in order to guarantee the required ISO or NAS class. Provide a filtering system in the circuit which guarantees the required ISO or NAS class. Start the system slowly unloaded, properly purging residual air before applying the load. Replace the filters after the first 50 hours of work. Replace the filter of the hydraulic circuit every 500 hours of work. Replace the hydraulic filter according to the supplier's specifications. If the hydraulic components do not work, do not insist in trying them to no avail; recheck the correct execution of the system and contact the technical service if needed.

#### FUNKTIONSEIGENSCHAFTEN

Die in dem vorliegenden Katalog dargestellten Kennlinien sind typisch für Produkte, die im Labor berechnet und getestet wurden, und sind nicht unbedingt für jede Einheit charakteristisch.

#### LAGERUNG

Die hydraulischen Komponenten sind in ihrer Verpackung in einem trockenen Raum, fern von Sonneneinstrahlung und Wärme- oder Ozonquellen, bei einer Umgebungstemperatur zwischen -20°C und +50°C aufzubewahren.

#### HYDRAULIKFLUID

Es wird empfohlen, Hydraulikfluide zu verwenden, die der Norm ISO 6743-4 entsprechen.

#### GRENZWERTE BETRIEBSTEMPERATUREN

Mindesttemperatur -20°C  
Höchsttemperatur (durchgehend) +85°C  
Höchsttemperatur (Spitzenwert) +100°C  
Der Betrieb mit dem Fluid bei einer Temperatur über +85°C führt zu einem vorzeitigen Verfall der Funktionseigenschaften der verwendeten Dichtungen. (NBR)

#### VISKOSITÄT

Es ist zu überprüfen, dass die Viskosität des Fluids für den einwandfreien Betrieb geeignet ist; mindestens 10 mm<sup>2</sup>/s (über kurze Zeiträume), höchstens 1000 mm<sup>2</sup>/s (über kurze Zeiträume beim Starten), empfohlene Viskosität 15-90 mm<sup>2</sup>/s.

#### BETRIEBSDRUCK EINGANGSSEITIG

Absoluter Höchstdruck:  
P min 0,8 bar - P max 2 bar

#### ABLAUSSDRUCK

Absoluter Höchstdruck: 2 bar

#### FILTRATIONSGRAD

Für Pumpen und Servosteuerungen wird folgende Reinheitsklasse empfohlen:  
Klasse ISO4406 20/18/15 (NAS1638 - 9)

#### INSTALLATION

Vor Inbetriebnahme der hydraulischen Komponenten, ist sicherzustellen, dass der gesamte Hydraulikkreis entsprechend mit Öl befüllt und entlüftet wurde. Das Öl für die Befüllung ist so zu filtern, dass die Einhaltung der geforderten ISO- oder NAS-Klassen gewährleistet werden kann. Im Kreislauf ist ein Filtrationssystem vorzusehen, das die Einhaltung der geforderten ISO- oder NAS-Klasse gewährleistet. Die Anlage langsam leer in Betrieb nehmen und vor Lastaufbringung die vorhandene Restluft vollständig entweichen lassen. Die Filter nach den ersten 50 Betriebsstunden auswechseln. Den Filter des Hydraulikkreises jeweils nach 500 Betriebsstunden auswechseln. Für den Austausch des Hydraulikfilters sind die Spezifikationen des Herstellers zu berücksichtigen. Bei einer Funktionsstörung der hydraulischen Komponenten den Betrieb unterbrechen, die korrekte Ausführung der Anlage überprüfen und gegebenenfalls den Technischen Kundendienst kontaktieren.

 Operare sempre prestando la massima attenzione agli organi in movimento; non utilizzare indumenti larghi o svolazzanti.

Non approssimarsi a ruote, cingoli, trasmissioni a catena o ad albero non adeguatamente protette ed in movimento, o che potrebbero iniziare a muoversi in qualsiasi istante senza preavviso.

Non svitare e scollegare raccordi e tubi con il motore in moto.

Evitare le fughe di olio, per prevenire l'inquinamento ambientale.

Non dirigere getti d'acqua direttamente sui componenti idraulici.

HP Hydraulic si solleva da ogni responsabilità riguardante la non osservanza di queste indicazioni e del rispetto delle normative di sicurezza vigenti, anche se non contemplate nel presente manuale.

 Always pay the utmost attention to moving parts when operating; do not wear wide or loose clothing.

Do not approach wheels, belts, chain or shaft transmissions which are inadequately protected or in movement or which could start moving suddenly without forewarning.

Do not unscrew or disconnect fittings and pipes with the motor running.

Avoid oil leakage to prevent environmental pollution.

Do not spray water directly on hydraulic components.

HP Hydraulic will not be held liable for failure to comply with these indications and with safety standards in force even if not considered in this manual.

 Bei Durchführung der Tätigkeiten immer besonders auf in Bewegung befindliche Elemente achten; keine weite oder flatternde Kleidung tragen. Sich niemals Rädern, Raupenketten, Ketten- oder Wellenantrieben nähern, die nicht ausreichend geschützt und in Bewegung sind bzw. sich jederzeit ohne Vorankündigung in Bewegung setzen könnten.

Niemals Verbindungsstücke und Rohre bei laufendem Motor lösen und entfernen. Zur Vorbeugung von Umweltverschmutzungen sind Ölkragen zu vermeiden. Niemals Wasserstrahlen direkt auf die Hydraulikkomponenten richten.

Im Fall der Nichtbeachtung dieser Anweisungen und der gültigen Sicherheitsnormen, auch wenn diese im vorliegenden Handbuch nicht angeführt, lehnt HP Hydraulic jegliche Verantwortung ab.

**MUST** come **Modular, Universal, Silence, Technology.**

**Modular** perché la nuova gamma di pompe multiple è altamente modulare e consente di combinare stadi silenziosi e standard di pompe in alluminio e in ghisa.

**Universal** perché le pompe silenziose HPZ in alluminio e HPX in ghisa utilizzano le basi, le estremità d'albero, i coperchi, le valvole combinate e gli accessori presenti nella gamma di pompe standard in alluminio HPL e in ghisa HPG.

**Silence** per la forte riduzione della rumorosità. La serie HPZ abbatta il livello di pressione sonora da 2 a 10 dB(A) rispetto alla corrispondente serie standard in alluminio HPL. La serie HPX ottiene sensibilmente i già ottimi risultati ottenuti con la serie standard in ghisa HPG.

**Technology** perché nasce dalla tecnologia e dall'esperienza Bondioli&Pavesi nella fabbricazione di ingranaggi.

Le gamme **MUST**, caratterizzate dal colore nero, si propongono per tutte le applicazioni mobili e fisse, agricole ed industriali, dove si rende necessario l'abbattimento del rumore o dove il legislatore imponga restrizioni di inquinamento acustico.

**MUST** as in **Modular, Universal, Silence, Technology.**

**Modular** because the new range of multiple pumps is highly modular and allows the combination of silent and standard stages in aluminum and cast iron pumps.

**Universal** because silent HPZ aluminum and HPX cast iron pumps use the bases, the shaft ends, the covers, the combined valves and the accessories found in the standard range of pumps, HPL aluminum and HPG cast iron.

**Silence** for the strong reduction of noise production. The HPZ series reduces the sound pressure level from 2 to 10 dB(A) in comparison with the corresponding standard aluminum series HPL. The HPX series appreciably improves the already excellent results obtained with the standard cast iron series HPG.

**Technology** because it springs from Bondioli&Pavesi technology and experience in gear manufacturing.

The **MUST** ranges, characterized by their black color, are proposed for all mobile and fixed, farming and industrial applications, where it is necessary to cut down noise or where the law imposes restrictions on noise pollution.

**MUST** kommt von **Modular, Universal, Stille, Technology.**

**Modular**, weil die neue Baureihe der leise laufenden Pumpen auch mit anderen Pumpen, wie einer Pumpe derselben Baureihe, als auch mit Standard-Aluminium- oder Gußpumpen kombiniert werden kann.

**Universal**, weil die leise laufenden Pumpen HPZ mit Aluminiumgehäuse und die HPX mit Gußgehäuse die gleichen Lager, Wellenenden, Deckel, Einbauventile und Zubehör der Standard-Baureihen HPL und HPG verwenden

**Stille** wegen der drastischen Reduzierung des Geräusches. Die Serie HPZ reduziert den Schalldruck um 2 bis 10 dB(A) im gleichen Betriebspunkt im Vergleich zur Standard-Pumpe mit Aluminiumgehäuse HPL. Die Pumpen der Serie HPX verbessern noch leicht die bereits sehr guten Werte, welche mit der Standard-Gußpumpe HPG erreicht werden.

**Technology**, weil diese Pumpen aus der Fertigungstechnik und der Erfahrung von Bondioli&Pavesi in der Herstellung von Zahnradkomponenten entstanden ist.

Die Pumpen der **MUST**-Baureihen sind elektrochemisch schwarz beschichtet und sind für alle mobilen und stationären Anwendungen geeignet, wo eine Reduzierung der Schalldruckemission sinnvoll ist oder wo der Gesetzgeber strenge Grenzwerte der Lärmbelästigung vorschreibt.

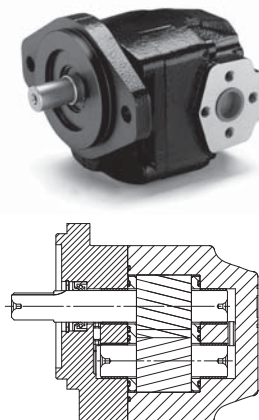
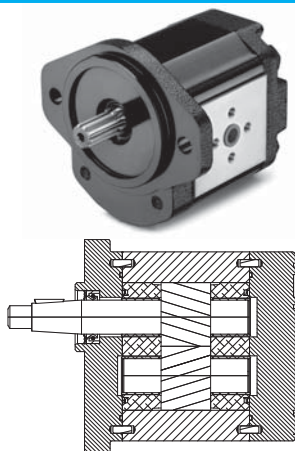



Le pompe oleodinamiche ad ingranaggi esterni comportano, ad alte pressioni, livelli di rumore e di vibrazione spesso troppo elevati per alcune applicazioni. Il rumore indotto dalla pompa si può suddividere in due forme identificate come "rumore meccanico", emesso dalla pompa stessa, e "rumore idraulico" causato dalla pulsazione del fluido che spesso è la sorgente primaria del rumore. A seguire esempio di pulsazione della portata istantanea riconducibile al "rumore idraulico" inteso come la ciclica variazione e spostamento di volume di fluido dalla bassa all'alta pressione. La ciclicità di queste variazioni induce pulsazioni che costituiscono la fonte di quel rumore effettivamente percepito all'esterno.

*External gear hydraulic pumps, when running at high pressure, can often generate too much noise and vibration not just for industrial applications but also agricultural ones.*

*The noise induced by the pump can be split into two types: "mechanical noise" emitted by the pump itself and "hydraulic noise" caused by the fluid being pumped, and often the primary source of noise.*

*Below is an example of pulsation of the instantaneous flow rate causing hydraulic noise, and considered the cyclical variation and movement in fluid volume from low to high pressure. The cyclical nature of these variations generates pulsations which are the source of the noise that is perceived from the outside.*

Außenzahnradpumpen haben bei hohen Betriebsdrücken für eine Reihe von Anwendungen zu hohe Geräusch- und Schwingungsniveaus.

Der von der Pumpe induzierte Schall lässt sich unterscheiden in eine "mechanische" und eine "hydraulische" Schallemission, welche durch die Pulsation der Fördermenge des Fluids häufig eine Geräuschquelle erster Ordnung.

Die dabei entstehende hydraulische Geräuschemission ist direkt auf die Volumenstrom-pulsation zurückzuführen, die bei der Förderung des Öls von der Nieder- zur Hochdruckseite auftritt.

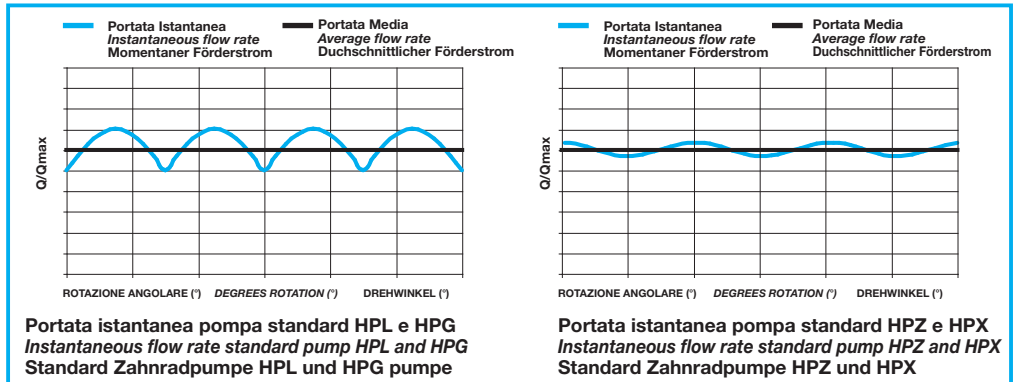

HP Hydraulic SpA ha sviluppato due gamme di pompe a ingranaggi a dentatura elicoidale. HPZ è la gamma di pompe silenziose in alluminio del gruppo 2 dedicate alle applicazioni mobili e agricole nelle quali è richiesto un abbattimento considerevole del livello di pressione sonora (dB(A)). HPX è la gamma di pompe silenziose in ghisa del gruppo 2 dedicate alle applicazioni heavy duty.

Le pompe a ingranaggi delle serie HPZ e HPX mantengono le performance, l'efficienza e l'affidabilità delle tradizionali serie HPL ed HPG, con il valore aggiunto della silenziosità. Le serie HPZ e HPX sono progettate seguendo la filosofia costruttiva **MUST**, che permette di avere intercambiabilità di componenti, versatilità nella composizione di pompe multiple e ampia scelta di valvole.

*HP Hydraulic SpA has developed two ranges of gear pumps with helical teeth.*

*HPZ is the range of silent aluminum pumps in group 2 dedicated to mobile and farming applications in which a considerable reduction of the sound pressure level is required (dB(A)).*

*HPX is the range of silent cast iron pumps in group 2 dedicated to heavy duty applications.*

*The gear pumps in series HPZ and HPX maintain the performance, efficiency and reliability of the traditional series HPL and HPG, with the added value of silent running. Series HPZ and HPX are designed according to the **MUST** construction ethic, which allows interchangeability of components, versatility in the composition of multiple pumps and a wide choice of valves.*

HP Hydraulic SpA hat zwei Baureihen von Zahnradpumpen mit Schrägverzahnung entwickelt.

Die Baureihe HPZ ist eine leise laufende Pumpe Gruppe 2 aus Aluminium, geeignet für mobile Arbeitsmaschinen und Landmaschinen, bei denen ein Bedarf zur erheblichen Reduzierung des Schalldruckpegels (dB(A)) besteht.

Die Baureihe HPX besteht aus leise laufenden Zahnradpumpen der Gruppe 2 mit Gußgehäuse, welche für schwere Anwendungen geeignet sind.

Die Zahnradpumpen der Serien HPZ und HPX haben dieselben Eigenschaften, Wirkungsgrade und Zuverlässigkeit, wie die bekannten Zahnradpumpen mit Geradverzahnung HPL und HPG, jedoch mit dem zusätzlichen Vorteil der geringen Schallemission.

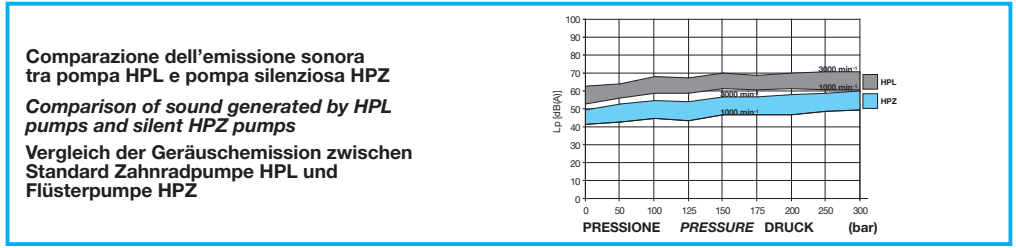

**DEFINIZIONE DEL VERSO DI ROTAZIONE GUARDANDO L'ALBERO DI TRASCINAMENTO**  
**DEFINITION OF ROTATION LOOKING AT THE DRIVE SHAFT**  
**BESTIMUNG DER DREHRICHTUNG MIT BLICK AUF DIE ANTRIEBSWELLE**

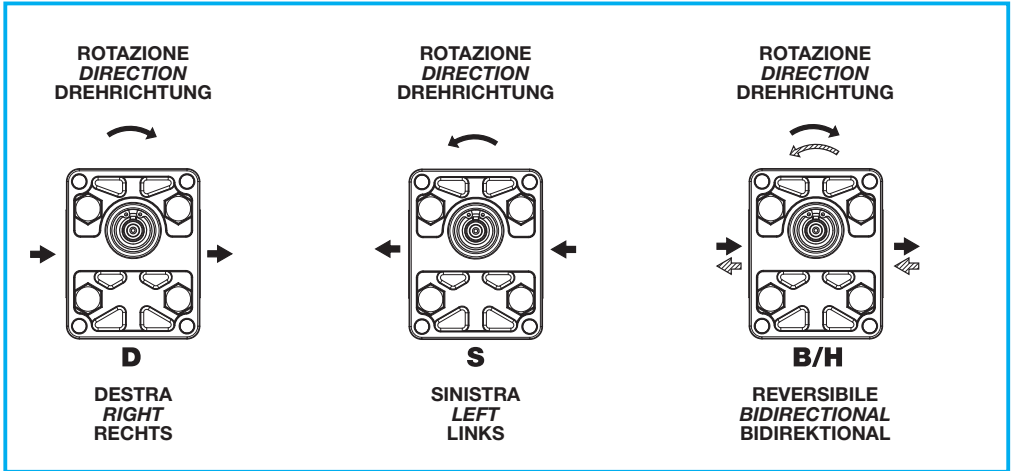

**FORMULE INERENTI A POMPE**  
**FORMULAS FOR PUMPS**  
**FORMELN FÜR PUMPEN**

**POMPA**  
**PUMP**  
**PUMPE**

$$Q = c \cdot \eta_v \cdot n \cdot 10^{-3} \quad [l/min]$$

$$M = \frac{\Delta p \cdot c}{62,83 \cdot \eta_m} \quad [Nm]$$

$$P = \frac{\Delta p \cdot c \cdot n}{600 \cdot 1000 \cdot \eta_t} \quad [kW]$$

<b>Q</b>	[l/min] Portata Flow rate Durchfluß	<b>c</b>	[cm <sup>3</sup> /giro] Cilindrata Displacement Fördervolumen	<b>η<sub>v</sub></b>	Rendimento volumetrico Volumetric efficiency Volumetrisch Leistungsfähigkeit
<b>M</b>	[Nm] Coppia Torque Drehmoment	<b>n</b>	[min <sup>-1</sup> ] nr. giri Speed Drehzahl	<b>η<sub>m</sub></b>	Rendimento meccanico Mechanical efficiency Mechanisch Leistungsfähigkeit
<b>P</b>	[kW] Potenza Power Leistung	<b>Δp</b>	[bar] Pressione Pressure Druck	<b>η<sub>t</sub>=η<sub>v</sub>η<sub>m</sub></b>	Rendimento totale Overall efficiency Gesamt Leistungsfähigkeit



**DEFINIZIONE DELLE PRESSIONI**  
**PRESSURE DEFINITION**  
**DRUCKBESTIMMUNGEN**

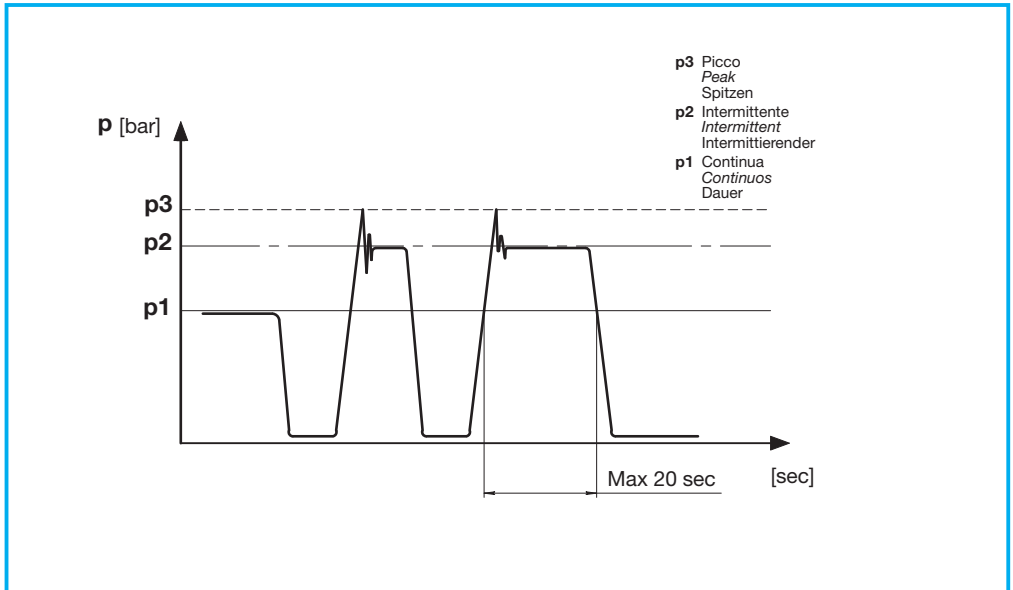

**COPPIE DI SERRAGGIO VITI**  
**SCREW TIGHTENING TORQUE**  
**SCHRAUBENANZUGSMOMENT**

Codice Code Code	Tipo vite Screw type Schraube Typ	Coppia min Min Torque Min Drehmomen [Nm]	Coppia max Max Torque Max Drehmoment [Nm]
HPZ..2	M10	43	45
HPZ..2	Versione SG SG Version SG Version	60	65
HPX..2	M10	70	75

POMPE  
PUMPS  
PUMPEN

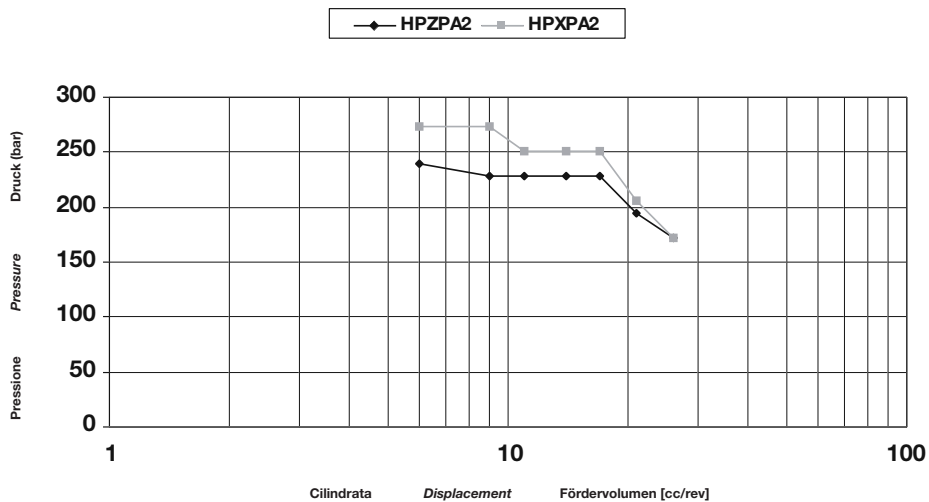



---

---

Questa pagina è intenzionalmente bianca  
*This page is intentionally blank*  
Diese Seite ist bewusst frei gelassen

# HPZ ..2

POMPE AD INGRANAGGI  
GEAR PUMPS  
ZAHNRADPUMPEN

*must*

# HPZ PA2

POMPE AD INGRANAGGI  
GEAR PUMPS  
ZAHNRADPUMPEN

DATI TECNICI  
TECHNICAL DATA  
TECHNISCHE MERKMALE



DIAGRAMMA PORTATE  
DIAGRAMS  
KENNLINIEN

GRUPPO GROUP BAUREIHE	TIPO TYPE TYP	CILINDRATA TEORICA NOMINAL DISPLACEMENT FÖRDERVOLUMEN (TM)		CONTINUA CONTINUOUS DAUER		PRESSIONE PRESSURE DRUCK INTERMITTENTE INTERMITTENT INTERMITTIERENDER		PICCO PEAK SPITZEN		VELOCITÀ DI ROTAZIONE SPEED DREHZAHL		MASSA WEIGHT GEWICHT	
		cm <sup>3</sup>	in <sup>3</sup>	bar	psi	bar	psi	bar	psi	MAX	MIN	kg	lbs
2	06	6,10	0,37	240	3481	260	3771	300	4351	3500	700	2,50	5,51
	09	9,00	0,55	230	3336	250	3626	280	4061			2,60	5,73
	11	11,50	0,70	230	3336	250	3626	280	4061			2,80	6,17
	14	14,20	0,87	230	3336	250	3626	280	4061	3000		3,00	6,61
	17	17,00	1,04	230	3336	250	3626	280	4061			3,10	6,83
	21	21,30	1,30	200	2901	220	3191	250	3626			3,40	7,49
	26	25,60	1,56	180	2611	190	2756	210	3046	2500		3,60	7,93

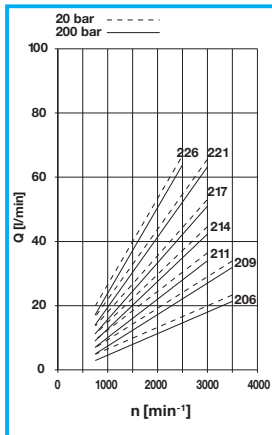



**DIMENSIONI  
SIZE  
ABMESSUNGEN**

**HPZ..2**

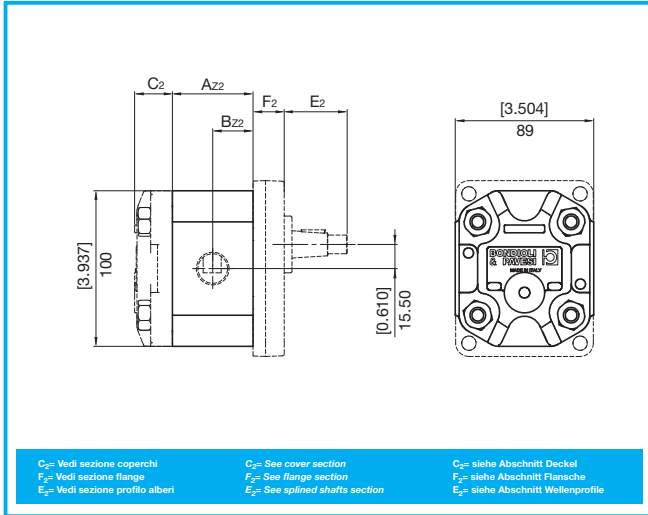

**DIMENSIONI  
SIZE  
ABMESSUNGEN**

TIPO TYPE TYPE	A <sub>22</sub>		B <sub>22</sub>	
	mm	in	mm	in
06	54,65	2,152	27,325	1,076
09	60,85	2,396	30,425	1,198
11	66,45	2,616	33,225	1,308
14	72,25	2,844	36,125	1,422
17	78,55	3,093	39,275	1,546
21	88,05	3,467	44,025	1,733
26	97,45	3,837	48,725	1,918

**COPERCHI  
COVERS  
DECKEL**

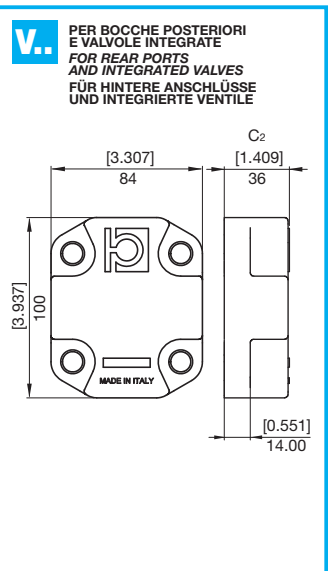
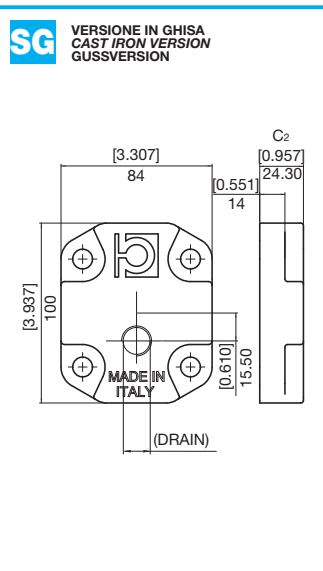
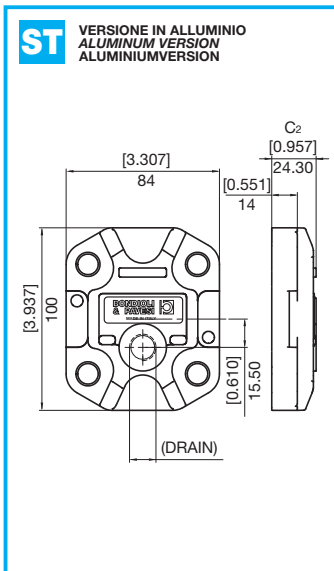

FLANGE  
FLANGES  
FLANSCHEN

VERSIONE IN GHISA  
CAST IRON VERSION  
GUSSVERSION

VERSIONE IN ALLUMINIO  
ALUMINUM VERSION  
ALUMINIUMVERSION

HPZ...2

L

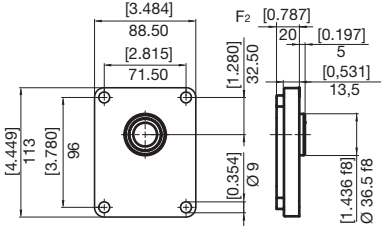

M

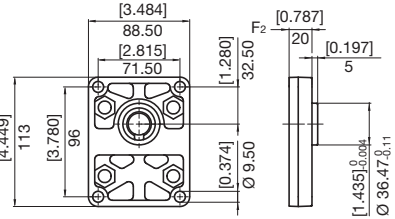

Q

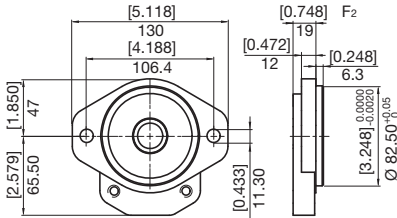

S

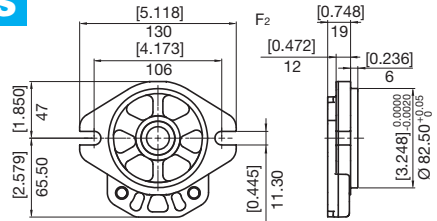

V

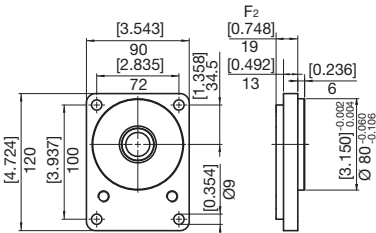

N

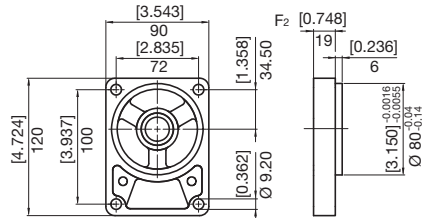

R

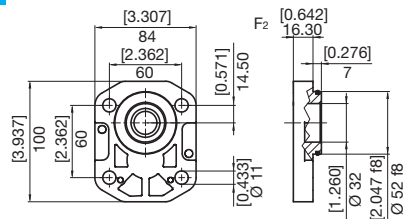



**PROFILO ALBERI  
SPLINE SHAFTS  
WELLENPROFILE**

**HPZ..2**

**L**

**COPPIA MAX  
MAX TORQUE  
MAX DREHMOMENT**

140 N•m

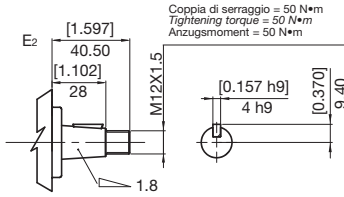

**M**

**COPPIA MAX  
MAX TORQUE  
MAX DREHMOMENT**

120 N•m

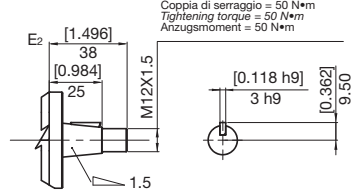

**P**

**COPPIA MAX  
MAX TORQUE  
MAX DREHMOMENT**

70 N•m

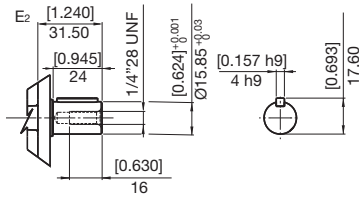

**N**

**COPPIA MAX  
MAX TORQUE  
MAX DREHMOMENT**

65 N•m

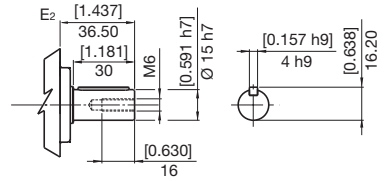

**Z**

**COPPIA MAX  
MAX TORQUE  
MAX DREHMOMENT**

70 N•m

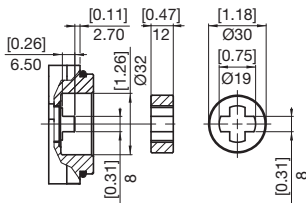

**V**

**COPPIA MAX  
MAX TORQUE  
MAX DREHMOMENT**

120 N•m

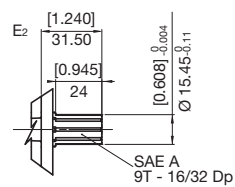

**E** LATERALE  
LATERAL  
SEITLICH

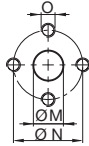

TIPO TYPE TYP	M		N		O	
	mm	in	mm	in		Nm
<b>E3</b>	13	0,51	30	1,18	M6	10
<b>E5</b>	20	0,79	40	1,57	M8	17

**X** LATERALE  
LATERAL  
SEITLICH

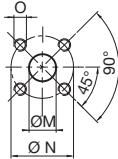

TIPO TYPE TYP	M		N		O	
	mm	in	mm	in		Nm
<b>X4</b>	15	0,59	35	1,38	M6	10
<b>X5</b>	15	0,59	40	1,57	M6	10
<b>X6</b>	20	0,79	40	1,57	M6	10
<b>X8</b>	27	1,06	55	2,57	M8	17

**G** LATERALE  
LATERAL  
SEITLICH

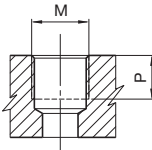

TIPO TYPE TYP		M		P	
			Nm	mm	in
<b>*G3</b>	3/8" GAS BSPP		38	12	0,47
<b>G4</b>	1/2" GAS BSPP		50	16	0,63
<b>G6</b>	3/4" GAS BSPP		90	19	0,75
<b>G7</b>	1" GAS BSPP		160	21	0,83

**U** LATERALE  
LATERAL  
SEITLICH

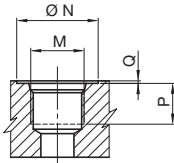

TIPO TYPE TYP	DIMENSIONE SIZE GRÖSSE	N		P		Q		M	
		mm	in	mm	in	mm	in		Nm
<b>*U3</b>	3/8"	25	0,98	13	0,51	0,3	0,01	9/16-18 UNF	25
<b>U5</b>	5/8"	34	1,34	17	0,67	0,3	0,01	7/8-14 UNF	70
<b>U6</b>	3/4"	41	1,61	19	0,75	0,3	0,01	1-1/16-12 UNF	90
<b>U7</b>	1"	49	1,93	20	0,79	0,3	0,01	1-5/16-12 UNF	160

**N** LATERALE  
LATERAL  
SEITLICH

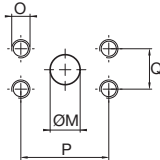

TIPO TYPE TYP	DIMENSIONE SIZE GRÖSSE	M		P		Q		O	
		mm	in	mm	in	mm	in		Nm
<b>N4</b>	1/2"	13	0,51	38,1	1,49	17,5	0,68	5/16-18UNC-2B	15
<b>N6</b>	3/4"	20	0,79	47,6	1,87	22,2	0,87	3/8"-16UNC-2B	25
<b>N7</b>	1"	27	1,06	52,4	2,60	26,2	1,03	3/8"-16UNC-2B	38

**M**

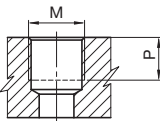

TIPO TYPE TYP	M		P	
		Nm	mm	in
<b>*M2</b>	M14x1,5	17	12	0,47

\* Drenaggio















\* Drain Port

\* Lecköl



**COMBINAZIONI  
COMBINATIONS  
KOMBINATIONEN**

**HPZ..2**

ESTREMITÀ ALBERO SHAFT PROFIL WELLESENDE	FLANGE FLANGE FLANSCH			
	<b>M</b> <b>L</b> 	<b>N</b> <b>V</b> 	<b>R</b> 	<b>S</b> <b>Q</b> 
<b>L</b> 	<input checked="" type="checkbox"/>			
<b>M</b> 		<input checked="" type="checkbox"/>		
<b>N</b> 	<input checked="" type="checkbox"/>			
<b>P</b> 				<input checked="" type="checkbox"/>
<b>V</b> 				<input checked="" type="checkbox"/>
<b>Z</b> 			<input checked="" type="checkbox"/>	
<b>BOCCHE PORTS ANSCHLÜSSE</b>				
<b>E</b> 	<input checked="" type="checkbox"/>			
<b>G</b> 	<input checked="" type="checkbox"/>			<input checked="" type="checkbox"/>
<b>X</b> 		<input checked="" type="checkbox"/>	<input checked="" type="checkbox"/>	
<b>U</b> 				<input checked="" type="checkbox"/>
<b>N</b> 				<input checked="" type="checkbox"/>

---

Questa pagina è intenzionalmente bianca  
*This page is intentionally blank*  
Diese Seite ist bewusst frei gelassen





**ISTRUZIONI PER L'ORDINAZIONE  
ORDERING INSTRUCTIONS  
BESTELLANLEITUNG**

**HPZ..2**



**SERIE**  
SERIES  
SERIE

**PRODOTTO**  
PRODUCT  
PRODUKT

PA - Pompa singola  
PA - Pump  
PA - Pumpe

**GRUPPO**  
GROUP  
BAUGRÖSSE

2

**CILINDRATA**  
DISPLACEMENT  
FÖRDERVOLUMEN

06 - 6,10  
09 - 9,00  
11 - 11,50  
14 - 14,20  
17 - 17,00  
21 - 21,30  
26 - 25,60

**SENSO DI ROTAZIONE**  
ROTATION  
DREHRICHTUNG

S - Antioraria/sinistra  
D - Oraria/destra  
H - Bidirezionale drenaggio interno  
B - Bidirezionale drenaggio esterno posteriore

S - Counterclockwise  
D - Clockwise  
H - Reversible ind. drain.  
B - Reversible rear. drain. pont.

S - Linkslauf  
D - Rechtslauf  
H - reversibel, Lecköl intern, Anschluß seitlich  
B - reversibel, Lecköl extern, Anschluß hinten

**SET VALVOLE**  
VALVE SETTING  
VENTILEINSTELLUNG  
(bar)

**COPERCHI - COVERS - DECKEL**  
ST - Standard  
SG - Versione in ghisa  
Cast iron version  
Gussversion

V. - Con valvole (Vedi sez. valvole GL013)  
With valves (See valves section GL013)  
Mit Ventilen  
(siehe Abschnitt Ventile GL013)

**GUARNIZIONI - SEALS - DICHTUNGEN**  
B - NBR V - Viton  
R - NBR alte pres. (25 bar) W - Viton alte pres. (25 bar)  
For high pres. (25 bar) For high pres. (25 bar)  
Hochdruck (25 bar) Hochdruck (25 bar)

**BOCCHIE STD - STANDARD PORT - STANDARD ANSCHLÜSSE**  
CILINDRATA - DISPLACEMENT - FÖRDER-/SCHLUCKVOLUMEN

6.....9		11.....21		26		DRAIN
Pompe - Pumps	Pumpen IN/OUT	Pompe - Pumps	Pumpen IN/OUT	Pompe - Pumps	Pumpen IN/OUT	
E3 E3		E5 E3		E5 E5		M2
G4 G4		G6 G4		G7 G6		G3
X5 X4		X6 X4		X8 X4		M2
U6 U5		U6 U5		U7 U6		U3
N4 N4		N6 N4		N7 N6		U3

**POMPE BIDIR. IN=OUT - REVERS. PUMP IN=OUT**  
BIDIREK.PUMPE IN=OUT

**FLANGIA ANTERIORE**  
FRONT FLANGE  
VORDERER FLANSCH

L - Europea in ghisa  
M - Europea  
N - Tedesca  
Q - SAE A 2 fori in ghisa  
R - Tedesca D 52  
S - SAE A 2 fori  
V - Tedesca in ghisa

L - European cast iron  
M - European  
N - German  
Q - SAE A 2 holes cast iron  
R - German D 52  
S - SAE A 2 holes  
V - German cast iron

L - EU-Norm Guß  
M - EU-Norm  
N - DIN-Norm  
Q - SAE A 2 Bohrungen Guß  
R - DIN-Norm D 52  
S - SAE A 2 Bohrungen  
V - Din gussversion

**ESTREMITÀ D'ALBERO**  
SHAFT PROFIL  
WELLENENDE

L - Conico (1:8)  
M - Conico (1:5)  
N - Cilindrico D15 europeo  
P - Cilindrico SAE "A"  
V - Scanalato SAE "A" 9T  
Z - Dente frontale

L - Tapered (1:8)  
M - Tapered (1:5)  
N - D15 European parallel shaft  
P - SAE "A" parallel shaft  
V - SAE "A" 9T splined  
Z - Tang drive

L - Kegel (1:8)  
M - Kegel (1:5)  
N - zylindrisch D15 (E-norm)  
P - zylindrisch SAE "A"  
V - Keilwelle SAE "A" 9T  
Z - Kreuzprofil

Le pompe multiple sono combinazioni di due o più sezioni trascinate da un unico albero. Il trascinamento delle sezioni che compongono la pompa multipla avviene per mezzo di giunti scanalati.

La pompa multipla così composta può avere aspirazione e mandata per ogni stadio oppure, laddove possibile, aspirazione unica e più mandate.

Per le singole sezioni valgono i valori riportati a catalogo con alcune limitazioni di pressione derivanti dalla coppia massima del giunto di trascinamento e dell'estremità di albero.

La velocità massima di una pompa multipla è limitata al valore minimo delle velocità massime delle singole sezioni.

A seguire un utile esempio per dimensionare correttamente la coppia trasmissibile all'estremità di albero e per ogni singolo stadio di una pompa doppia gruppo 2 + gruppo 2 a determinate pressioni di esercizio su ogni stadio.

*Multiple pumps are combinations of two or more stages driven by one shaft. The rear pumps are driven by splined couplings.*

*The multiple pumps can have individual inlet and outlet ports for each stage or wherever possible a common inlet and separate outlet ports.*

*The technical features acc. data sheet of the present catalogue are valid for each stage, taking into consideration the limitations of transmissible torque of each coupling and the drive shaft.*

*The max. speed of the multiple pump is limited by the lowest max. speed of the individual stages.*

*Please follow the example of calculation for the correct projecting of the torque to be transmitted by the shaft and each coupling, here we calculate the admissible pressure for each stage of a double pump consisting of group 2 + group 2.*

Mehrfachpumpen sind Pumpenkombinationen von mindestens zwei Stufen, die von einer Welle angetrieben werden. Die hinteren Pumpen werden von verzahnten Kupplungen angetrieben.

Mehrfachpumpen können je Stufe einen separaten Saug- und Druckschluss haben oder, wo möglich, einen gemeinsamen Sauganschluss und getrennte Druckschlüsse. Die technischen Daten für die einzelnen Stufen sind entsprechend dem Datenblatt dieses Katalogs, wobei das übertragbare Drehmoment der Antriebswelle und der Zwischenkupplungen beachtet werden muß.

Die Höchstdrehzahl der Mehrfachpumpe wird bestimmt von der niedrigsten Höchstdrehzahl der einzelnen Stufen.

Um das zulässigste Drehmoment nicht zu überschreiten, berechnen Sie den zulässigen Betriebsdruck entsprechend dem nachfolgenden Beispiel, hier eine Doppelpumpe, bestehend aus einer Kombination von Gr.2 + Gr.2

### ESEMPIO POMPA DOPPIA:

#### HPZPB226DMLE5E5B211E3E3ST

La formula del calcolo della coppia da impiegare è:

$$M = \frac{\Delta p \cdot c}{62,83 \cdot \eta_m} \quad [Nm]$$

dove:

- M = Coppia (Nm)
- ΔP = Pressione (bar)
- c = Cilindrata pompa (cm<sup>3</sup>)
- 62,83 = Fattore di conversione
- η<sub>m</sub> = Rendimento meccanico = 0,9

Il calcolo si svolge partendo dall'ultimo stadio della pompa risalendo fino all'albero primario. In tutti gli stadi il risultato della coppia calcolata deve essere minore o uguale alla coppia massima ammissibile di ciascun giunto di trascinamento, compreso l'estremità d'albero della pompa.

#### Stadio 2:

- Cilindrata 11,5 cm<sup>3</sup>
- Pressione di funzionamento 210 bar:
- M<sub>2</sub> = 42,7 Nm.
- La condizione del giunto intermedio è soddisfatta (limite massimo 100 Nm).

#### Stadio 1:

- Cilindrata 25,6 cm<sup>3</sup>
- Pressione di funzionamento 160 bar:
- M<sub>1</sub> = 72,2 Nm
- M<sub>1</sub> + M<sub>2</sub> = 114,9 Nm.

La condizione dell'albero conduttore è soddisfatta (limite massimo 140 Nm).

### EXAMPLE OF DOUBLE PUMP:

#### HPZPB226DMLE5E5B211E3E3ST

The calculation formula of the torque to use is:

$$M = \frac{\Delta p \cdot c}{62,83 \cdot \eta_m} \quad [Nm]$$

where:

- M = Torque (Nm)
- ΔP = Pressure (bar)
- c = Pump displacement (cm<sup>3</sup>)
- 62,83 = Conversion factor
- η<sub>m</sub> = Mechanical efficiency = 0,9

The calculation is made from the last stage of the pump and going back as far as the main shaft. At all stages the result of the calculated torque must be less than or equal to the maximum permissible torque of each drive joint, including the pump shaft profile.

#### Stage 2:

- Displacement 11,5 cm<sup>3</sup>
- Operating pressure 210 bar:
- M<sub>2</sub> = 42,7 Nm
- The intermediate joint condition is satisfied (maximum limit 100 Nm).

#### Stage 1:

- Displacement 25,6 cm<sup>3</sup>
- Operating pressure 160 bar:
- M<sub>1</sub> = 72,2 Nm
- M<sub>1</sub> + M<sub>2</sub> = 114,9 Nm.

The condition of the driving shaft is met (max limit 140 Nm).

### BEISPIEL EINER DOPPELPUMPE:

#### HPZPB226DMLE5E5B211E3E3ST

Formel zur Berechnung des erforderlichen Drehmoments:

$$M = \frac{\Delta p \cdot c}{62,83 \cdot \eta_m} \quad [Nm]$$

wobei:

- M = Drehmoment (Nm)
- ΔP = Druck (bar)
- c = Fördervolumen der Pumpe (cm<sup>3</sup>)
- 62,83 = Umrechnungsfaktor
- η<sub>m</sub> = mechanischer Wirkungsgrad = 0,9

Die Berechnung erfolgt ausgehend von der letzten Stufe der Pumpe bis hin zur Hauptwelle. In allen Stufen muss das Ergebnis des berechneten Drehmoments kleiner oder gleich dem Wert des zulässigen Höchst Drehmoments jeder Mitnehmerwelle, einschließlich Wellenende der Pumpe, sein.

#### Stufe 2:

- Fördervolumen 11,5 cm<sup>3</sup>
- Betriebsdruck 210 bar:
- M<sub>2</sub> = 42,7 Nm.
- Die Bedingung der Mitnehmerwelle ist erfüllt (Höchstgrenze 100 Nm).

#### Stufe 1:

- Fördervolumen 25,6 cm<sup>3</sup>
- Betriebsdruck 160 bar:
- M<sub>1</sub> = 72,2 Nm
- M<sub>1</sub> + M<sub>2</sub> = 114,9 Nm.

Die Bedingung der Antriebswelle ist erfüllt (Höchstgrenze 140 Nm).

PER LE DIMENSIONI  
DELLE SINGOLE SEZIONI  
VEDERE IL GRUPPO DI RIFERIMENTO

FOR DIMENSION OF EACH SECTION  
REFER TO THE GROUP  
DIMENSION TABLE

DIE ABMESSUNGEN DER EINZELNEN  
PUMPEN ENTNEHMEN SIE BITTE DER  
ENTSPRECHENDEN TABELLE.

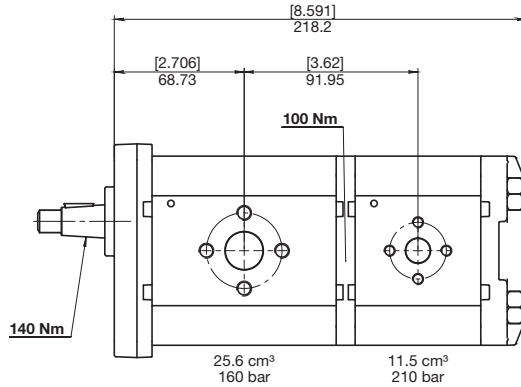

**1°** STADIO  
STAGE  
STUFE

**2°** STADIO  
STAGE  
STUFE

1° STADIO - STAGE - STUFE

**HPZ** **PB** **2** **26** **D** **M** **L** **E5E5** **B**

2° STADIO - STAGE - STUFE

**Z** **2** **11** **E3E3** **ST**

GIUNTO DI ACCOPIAMENTO  
COUPLING JOINT  
WELLENKUPPLUNG

GIUNTO DI ACCOPIAMENTO COUPLING JOINT WELLENKUPPLUNG	COPPIA MASSIMA TRASMISSIBILE MAXIMUM TRANSMITTED TORQUE MAX. ÜBERTRAGBARES DREHMOMENT
HPZP•2 + HPZP•2	<b>100 N•m</b>
HPXP•2 + HPXP•2	
HPZP•2 + HPLP•2	
HPXP•2 + HPGP•2	

**HPZP.2+HPZP.2**

**HPZP.2+HPLP.2**

**HPLP.2+HPZP.2**

POMPA A STADI SEPARATI  
SEPARATE TANKS PUMP  
UNTERSCHIEDLICHEPUMPE  
BEHÄLTNER

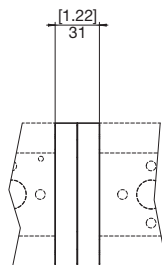
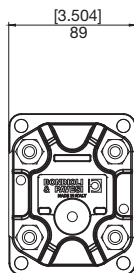
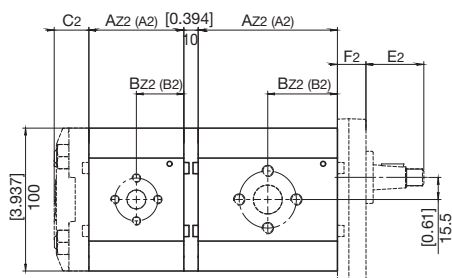

Per HPZP2+HPLP2 cilindrata secondo stadio < = 26 cc.  
For HPZP2+HPLP2 displacement of 2nd stage < = 26 cc.  
Für HPZP2+HPLP2 Fördervolumen der 2.Stufe < = 26 cc.

---

---

Questa pagina è intenzionalmente bianca  
*This page is intentionally blank*  
Diese Seite ist bewusst frei gelassen

## ISTRUZIONI PER L'ORDINAZIONE ORDERING INSTRUCTIONS BESTELLANLEITUNG

### 1° STADIO (Descrizione dello Stadio Stage Description - Stufe-Benennung)

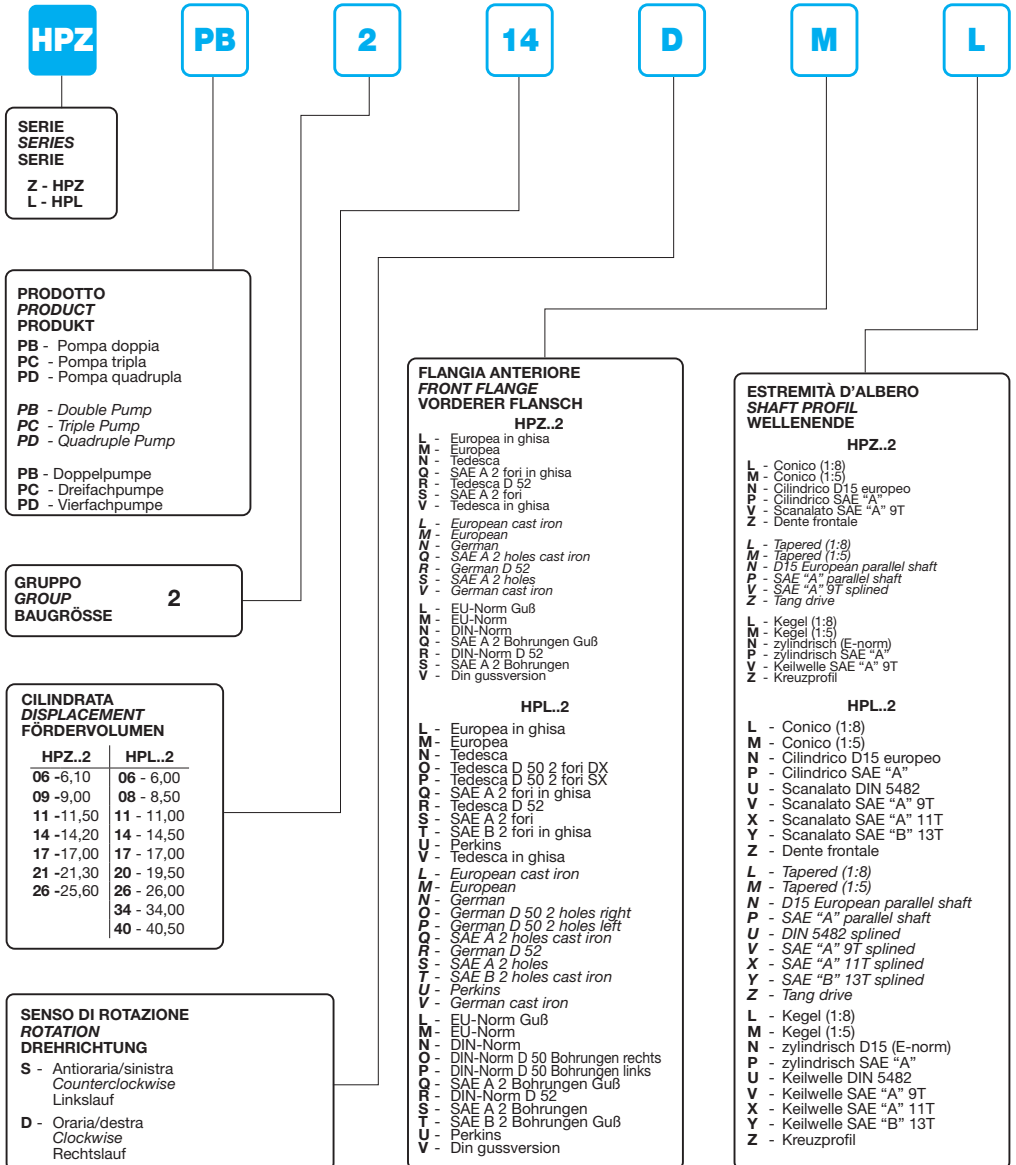



2° STADIO (Descrizione dello Stadio  
Stage Description - Stufe-Benennung)

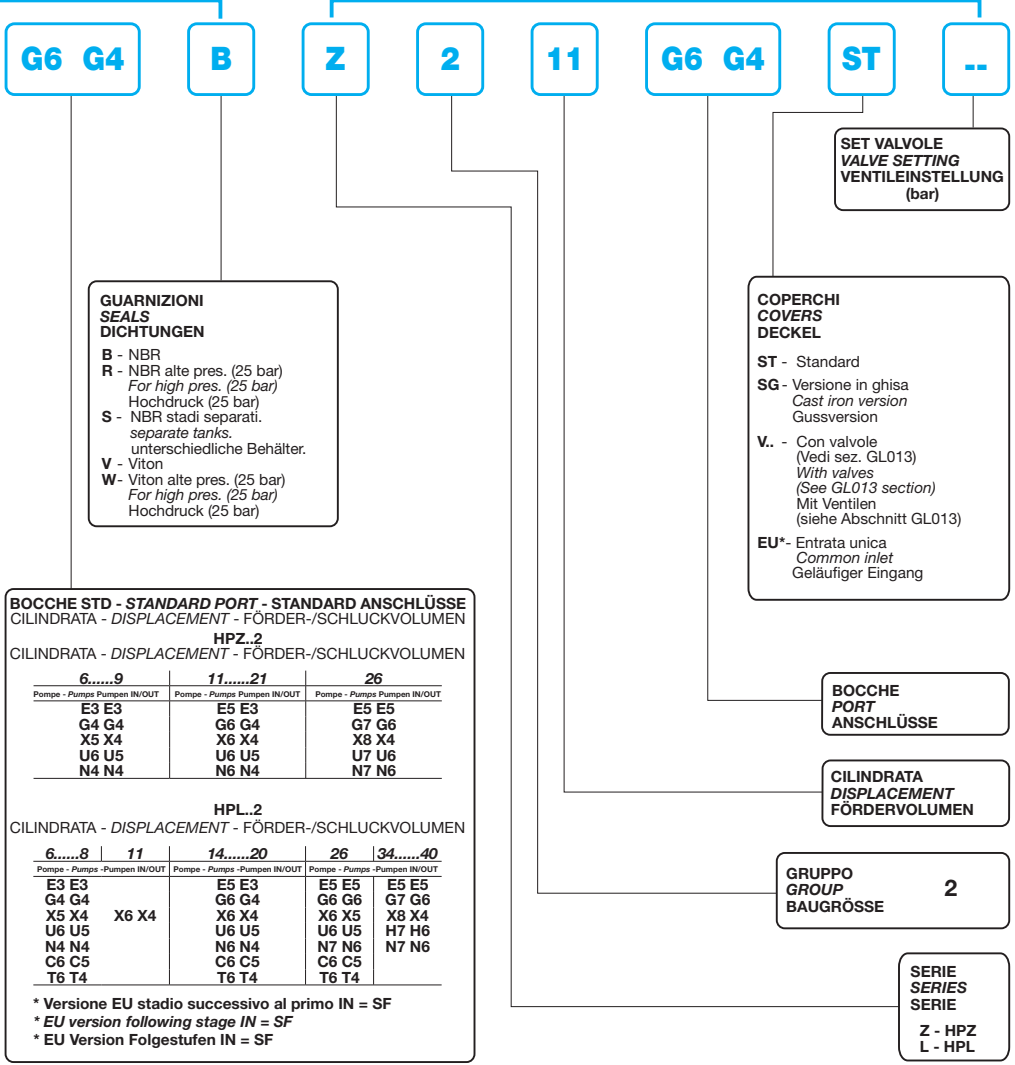

PER OGNI STADIO AGGIUNTO RIPETERE LA DESCRIZIONE      DESCRIPTION TO BE REPEATED FOR EVERY ADDED SECTION      FÜR JEDE STUFE BITTE DIE BESCHREIBUNG WIEDERHOLEN.

# HPX ..2

POMPE AD INGRANAGGI  
GEAR PUMPS  
ZAHNRADPUMPEN

*must*

# HPX PA2

POMPE AD INGRANAGGI  
GEAR PUMPS  
ZAHNRADPUMPEN

DATI TECNICI  
TECHNICAL DATA  
TECHNISCHE MERKMALE



DIAGRAMMA PORTATE  
DIAGRAMS  
KENNLINIEN

GRUPPO GROUP BAUREIHE	TIPO TYPE TYP	CILINDRATA TEORICA NOMINAL DISPLACEMENT FÖRDERVOLUMEN (TM)		CONTINUA CONTINUOUS DAUER		PRESSIONE PRESSURE DRUCK INTERMITTENTE INTERMITTENT INTERMITTIERENDER				VELOCITÀ DI ROTAZIONE SPEED DREHZAHL		MASSA WEIGHT GEWICHT	
		cm <sup>3</sup>	in <sup>3</sup>	bar	psi	bar	psi	bar	psi	MAX	MIN	kg	lbs
2	06	6,10	0,37	270	3916	290	4206	320	4641	3500	500	4,46	9,84
	09	9,00	0,55	270	3916	290	4206	320	4641			4,65	10,24
	11	11,50	0,70	250	3626	270	3916	300	4351	3000	4,86	10,72	
	14	14,20	0,87	250	3626	270	3916	300	4351		5,41	11,93	
	17	17,00	1,04	250	3626	270	3916	280	4061		5,64	12,44	
	21	21,30	1,30	210	3046	230	3336	250	3626		5,84	12,87	
26	25,60	1,56	180	2611	190	2756	210	3046	2500	6,71	14,79		

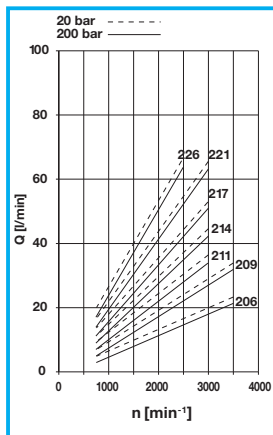





**DIMENSIONI  
SIZE  
ABMESSUNGEN**

**BOCCHIE LATERALI  
LATERAL PORTS  
SEITLICHANSCHLÜSSE**

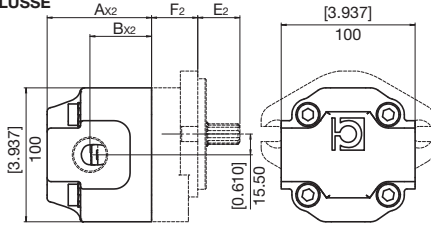

**BOCCHIE POSTERIORI  
REAR PORTS  
HINTENANSCHLÜSSE**

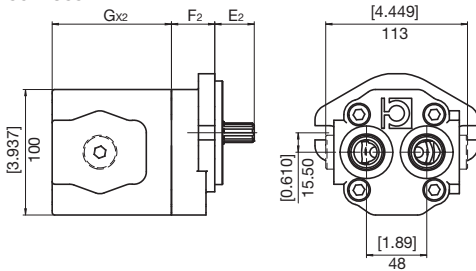

F<sub>2</sub>= Vedi sezione flange  
E<sub>2</sub>= Vedi sezione profilo alberi

F<sub>2</sub>= See flange section  
E<sub>2</sub>= See splined shafts section

F<sub>2</sub>= siehe Abschnitt Flansche  
E<sub>2</sub>= siehe Abschnitt Wellenprofile

**DIMENSIONI  
SIZE  
ABMESSUNGEN**

GRUPPO GROUP BAUREIHE	TIPO TYPE TYF	A <sub>x2</sub>		B <sub>x2</sub>		G <sub>x2</sub>	
		mm	in	mm	in	mm	in
<b>2</b>	<b>06</b>	53,8	2,12	32,8	1,29	61,3	2,41
	<b>09</b>	60	2,36	39	1,54	67,5	2,66
	<b>11</b>	68,2	2,69	36,2	1,43	73,2	2,88
	<b>14</b>	74	2,91	42	1,65	79	3,11
	<b>17</b>	77,5	3,05	47	1,85	85	3,35
	<b>21</b>	87	3,43	56,5	2,22	94,5	3,72
<b>26</b>	96,4	3,80	65,9	2,59	103,9	4,09	

**FLANGE  
FLANGES  
FLANSCH**

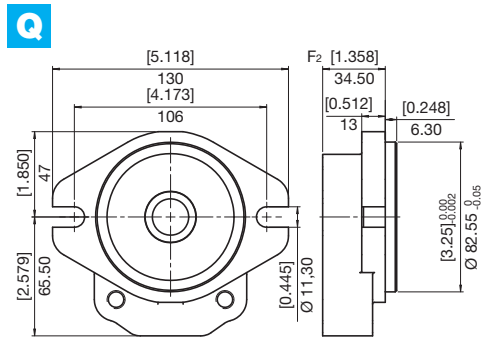
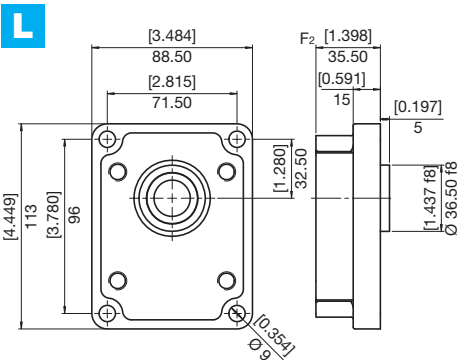

**L**

**COPPIA MAX  
MAX TORQUE  
MAX DREHMOMENT**

140 N•m

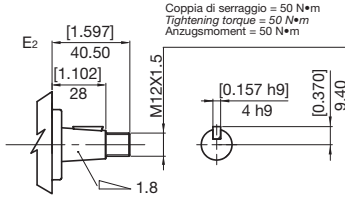

**V**

**COPPIA MAX  
MAX TORQUE  
MAX DREHMOMENT**

120 N•m

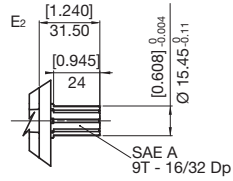

**N**

**COPPIA MAX  
MAX TORQUE  
MAX DREHMOMENT**

65 N•m

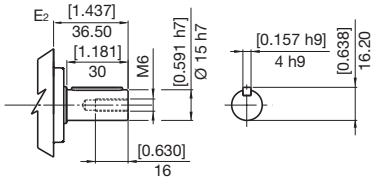

**P**

**COPPIA MAX  
MAX TORQUE  
MAX DREHMOMENT**

70 N•m

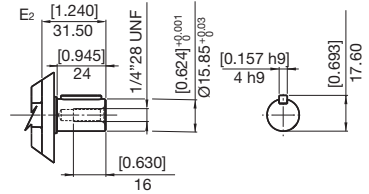



**BOCCHIE  
PORTS  
ANSCHLÜSSE**

**HPX..2**

<b>E</b>	LATERALE LATERAL SEITLICH		TIPO TYPE TYP	<b>M</b>		<b>N</b>		<b>O</b>	
				mm	in	mm	in		Nm
			<b>E3</b>	13	0,51	30	1,18	M6	10
			<b>E5</b>	20	0,79	40	1,57	M8	17
<b>E7</b>	27	1,06	51	2,01	M10	30			

<b>X</b>	LATERALE LATERAL SEITLICH		TIPO TYPE TYP	<b>M</b>		<b>N</b>		<b>O</b>	
				mm	in	mm	in		Nm
			<b>X4</b>	15	0,59	35	1,38	M6	10
			<b>X5</b>	15	0,59	40	1,57	M6	10
<b>X6</b>	20	0,79	40	1,57	M6	10			

<b>G</b> <b>T</b>	LATERALE LATERAL SEITLICH POSTERIORE REAR HINTEN		TIPO TYPE TYP	<b>M</b>		<b>P</b>	
					Nm	mm	in
			<b>*G3</b>	3/8" GAS BSPP	38	12	0,47
			<b>G4</b>	1/2" GAS BSPP	70	16	0,63
			<b>G6</b>	3/4" GAS BSPP	90	19	0,75
			<b>G7</b>	1" GAS BSPP	160	21	0,83
			<b>T4</b>	1/2" GAS BSPP	70	16	0,63
			<b>T6</b>	3/4" GAS BSPP	90	19	0,75
			<b>T7</b>	1" GAS BSPP	160	21	0,83

<b>U</b> <b>C</b>	LATERALE LATERAL SEITLICH POSTERIORE REAR HINTEN		TIPO TYPE TYP	DIMENSIONE SIZE GRÖSSE	<b>N</b>		<b>P</b>		<b>Q</b>		<b>M</b>	
					mm	in	mm	in	mm	in		Nm
			<b>*U3</b>	3/8"	25	0,98	13	0,51	0,3	0,01	9/16-18 UNF	25
			<b>U5</b>	5/8"	34	1,34	17	0,67	0,3	0,01	7/8-14 UNF	70
			<b>U6</b>	3/4"	41	1,61	19	0,75	0,3	0,01	1-1/16-12 UNF	90
			<b>U7</b>	1"	49	1,93	20	0,79	0,3	0,01	1-5/16-12 UNF	160
			<b>C5</b>	5/8"	34	1,34	17	0,67	0,3	0,01	7/8-14 UNF	70
			<b>C6</b>	3/4"	41	1,61	19	0,75	0,3	0,01	1-1/16-12 UNF	90
			<b>C7</b>	1"	49	1,93	20	0,79	0,3	0,01	1-5/16-12 UNF	160

<b>N</b>	LATERALE LATERAL SEITLICH		TIPO TYPE TYP	DIMENSIONE SIZE GRÖSSE	<b>M</b>		<b>P</b>		<b>Q</b>		<b>O</b>	
					mm	in	mm	in	mm	in		Nm
			<b>N4</b>	1/2"	13	0,51	38,1	1,49	17,5	0,68	5/16-18UNC-2B	17
			<b>N6</b>	3/4"	20	0,79	47,6	1,87	22,2	0,87	3/8"-16UNC-2B	38
			<b>N7</b>	1"	27	1,06	52,4	2,60	26,2	1,03	3/8"-16UNC-2B	38











<b>F</b>	LATERALE LATERAL SEITLICH		TIPO TYPE TYP	DIMENSIONE SIZE GRÖSSE	<b>M</b>		<b>P</b>		<b>Q</b>		<b>O</b>	
					mm	in	mm	in	mm	in		Nm
			<b>F4</b>	1/2"	13	0,51	38,1	1,49	17,5	0,68	M8	17
			<b>F6</b>	3/4"	20	0,79	47,6	1,87	22,2	0,87	M10	38
			<b>F7</b>	1"	25,4	1,06	52,4	2,60	26,2	1,03	M10	38

<b>M</b>		TIPO TYPE TYP	<b>M</b>		<b>P</b>	
				Nm	mm	in
		<b>*M2</b>	M14x1,5	17	12	0,47

\* Drenaggio

\* Drain Port

\* Lecköl

ESTREMITÀ ALBERO SHAFT PROFIL WELLESENDE	Q 	FLANGE FLANGE FLANSCH	L 
L 			■
N 			■
P 	■		
V 	■		
BOCCHIE PORTS ANSCHLÜSSE			
E 			■
X 			■
GT 	■		■
UC 	■		
N F 	■		



**ISTRUZIONI PER L'ORDINAZIONE**  
**ORDERING INSTRUCTIONS**  
**BESTELLANLEITUNG**

**HPX..2**

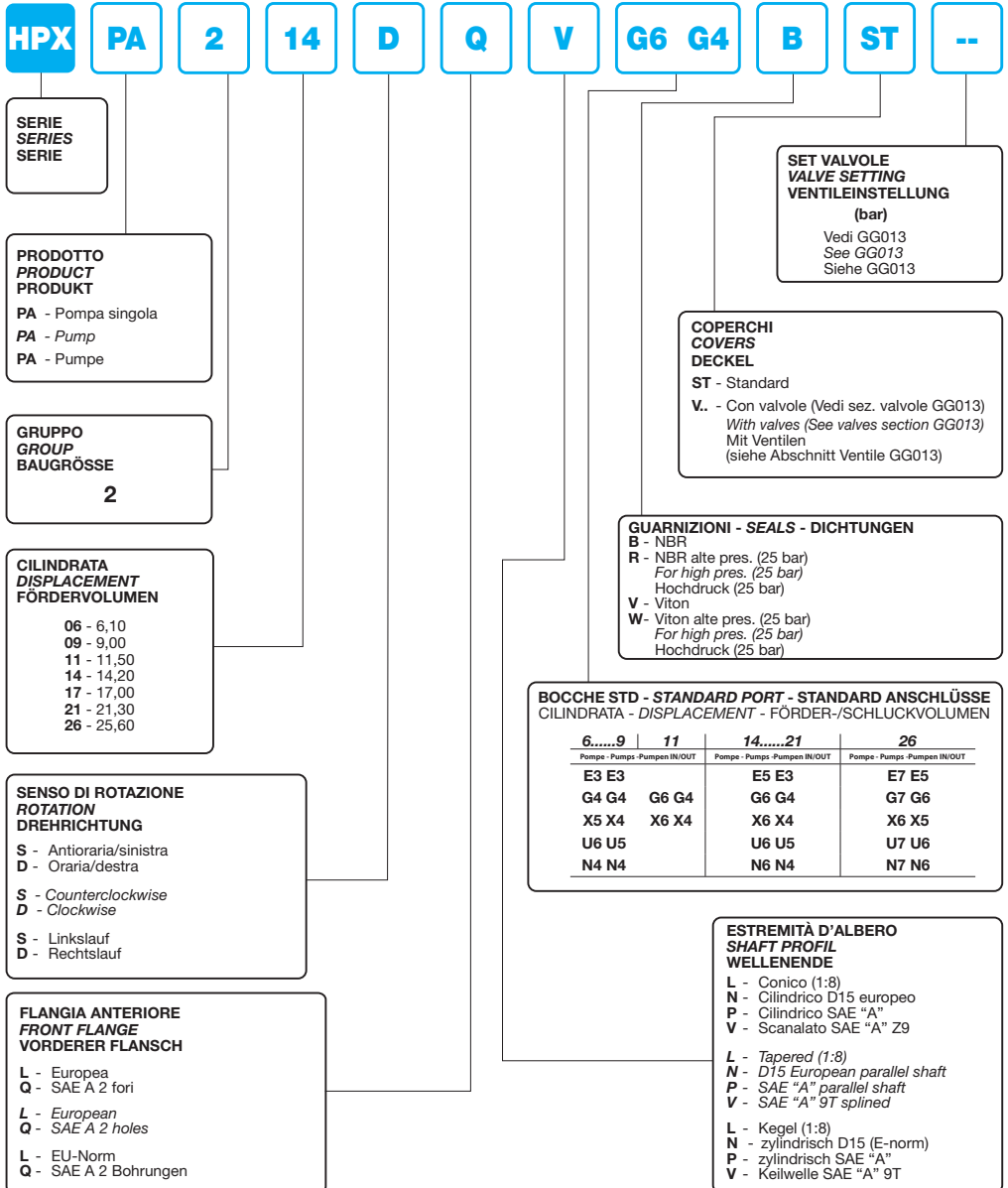

**HPX**

**PA**

**2**

**14**

**D**

**Q**

**V**

**G6 G4**

**B**

**ST**

**--**

**SERIE**  
**SERIES**  
**SERIE**

**PRODOTTO**  
**PRODUCT**  
**PRODUKT**

PA - Pompa singola  
PA - Pump  
PA - Pumpe

**GRUPPO**  
**GROUP**  
**BAUGRÖSSE**

**2**

**CILINDRATA**  
**DISPLACEMENT**  
**FÖRDERVOLUMEN**

06 - 6,10  
09 - 9,00  
11 - 11,50  
14 - 14,20  
17 - 17,00  
21 - 21,30  
26 - 25,60

**SENDO DI ROTAZIONE**  
**ROTATION**  
**DREHRICHTUNG**

S - Antioraria/sinistra  
D - Oraria/destra

S - Counterclockwise  
D - Clockwise

S - Linkslauf  
D - Rechtslauf

**FLANGIA ANTERIORE**  
**FRONT FLANGE**  
**VORDERER FLANSCH**

L - Europea  
Q - SAE A 2 fori

L - European  
Q - SAE A 2 holes

L - EU-Norm  
Q - SAE A 2 Bohrungen

**SET VALVOLE**  
**VALVE SETTING**  
**VENTILEINSTELLUNG**

(bar)

Vedi GG013  
See GG013  
Siehe GG013

**COPERCHI**  
**COVERS**  
**DECKEL**

ST - Standard

V. - Con valvole (Vedi sez. valvole GG013)  
With valves (See valves section GG013)  
Mit Ventilen  
(siehe Abschnitt Ventile GG013)

**GUARNIZIONI - SEALS - DICHTUNGEN**

B - NBR  
R - NBR alte pres. (25 bar)  
For high pres. (25 bar)  
Hochdruck (25 bar)

V - Viton  
W - Viton alte pres. (25 bar)  
For high pres. (25 bar)  
Hochdruck (25 bar)

**BOCCHE STD - STANDARD PORT - STANDARD ANSCHLÜSSE**  
**CILINDRATA - DISPLACEMENT - FÖRDER-/SCHLÜCKVOLUMEN**

6.....9		11	14.....21		26
Pompe - Pumps - Pumpen IN/OUT		Pompe - Pumps - Pumpen IN/OUT	Pompe - Pumps - Pumpen IN/OUT		Pompe - Pumps - Pumpen IN/OUT
E3	E3	E5	E3	E3	E7
G4	G4	G6	G4	G4	G7
X5	X4	X6	X4	X4	X6
U6	U5	U6	U5	U5	U7
N4	N4	N6	N4	N4	N7

**ESTREMITÀ D'ALBERO**  
**SHAFT PROFIL**  
**WELLENENDE**

L - Conico (1:8)  
N - Cilindrico D15 europeo  
P - Cilindrico SAE "A"  
V - Scanalato SAE "A" Z9

L - Tapered (1:8)  
N - D15 European parallel shaft  
P - SAE "A" parallel shaft  
V - SAE "A" 9T splined

L - Kegel (1:8)  
N - zylindrisch D15 (E-norm)  
P - zylindrisch SAE "A"  
V - Keilwelle SAE "A" 9T

## HPXP•2+HPXP•2

## HPXP•2+HPGP•2

## HPGP•2+HPXP•2

CILINDRATA  
DISPLACEMENT  
FÖRDER-/SCHLUCKVOLUMEN

Z <sub>x2</sub>	6...9		11...14		17...26	
	mm	in	mm	in	mm	in
Z <sub>x2</sub>	26,5	1,04	35	1,38	36	1,42

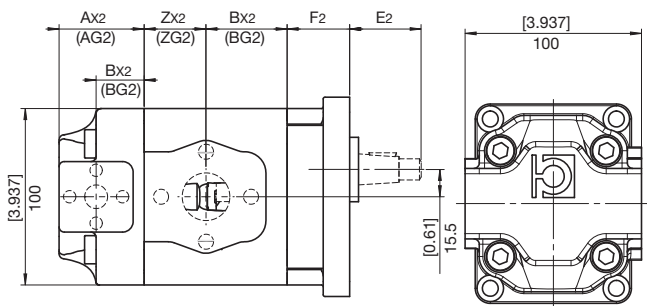

Per HPXP2+HPGP2 cilindrata secondo stadio <= 26 cc.  
For HPXP2+HPGP2 displacement of 2nd stage <= 26 cc.  
Für HPXP2+HPGP2 Fördervolumen der 2. Stufe <= 26 cc.

---

---

Questa pagina è intenzionalmente bianca  
*This page is intentionally blank*  
Diese Seite ist bewusst frei gelassen

**ISTRUZIONI PER L'ORDINAZIONE**  
**ORDERING INSTRUCTIONS**  
**BESTELLANLEITUNG**

**1° STADIO (Descrizione dello Stadio)**  
**Stage Description - Stufe-Benennung**

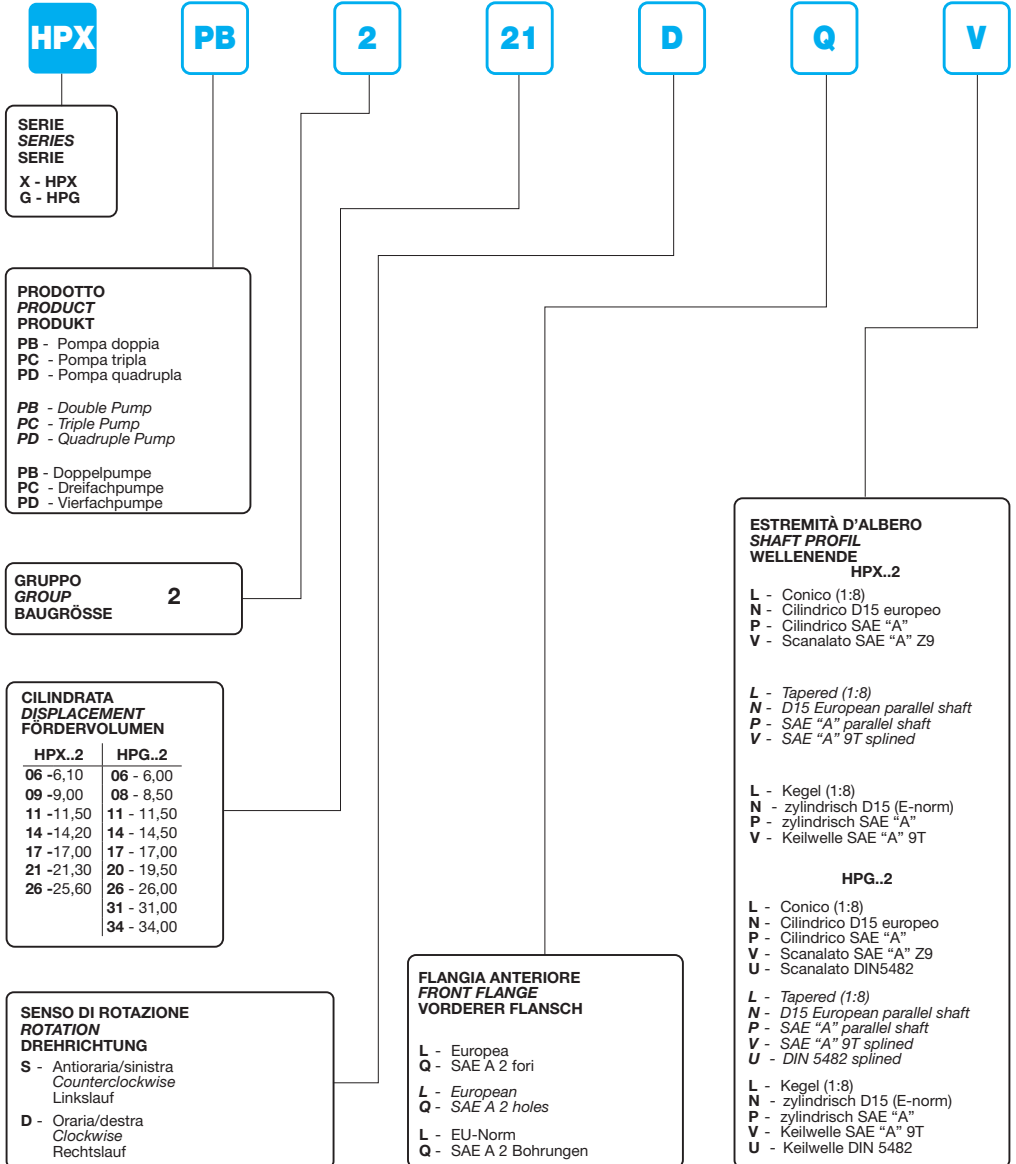





**2° STADIO (Descrizione dello Stadio  
Stage Description - Stufe-Benennung)**

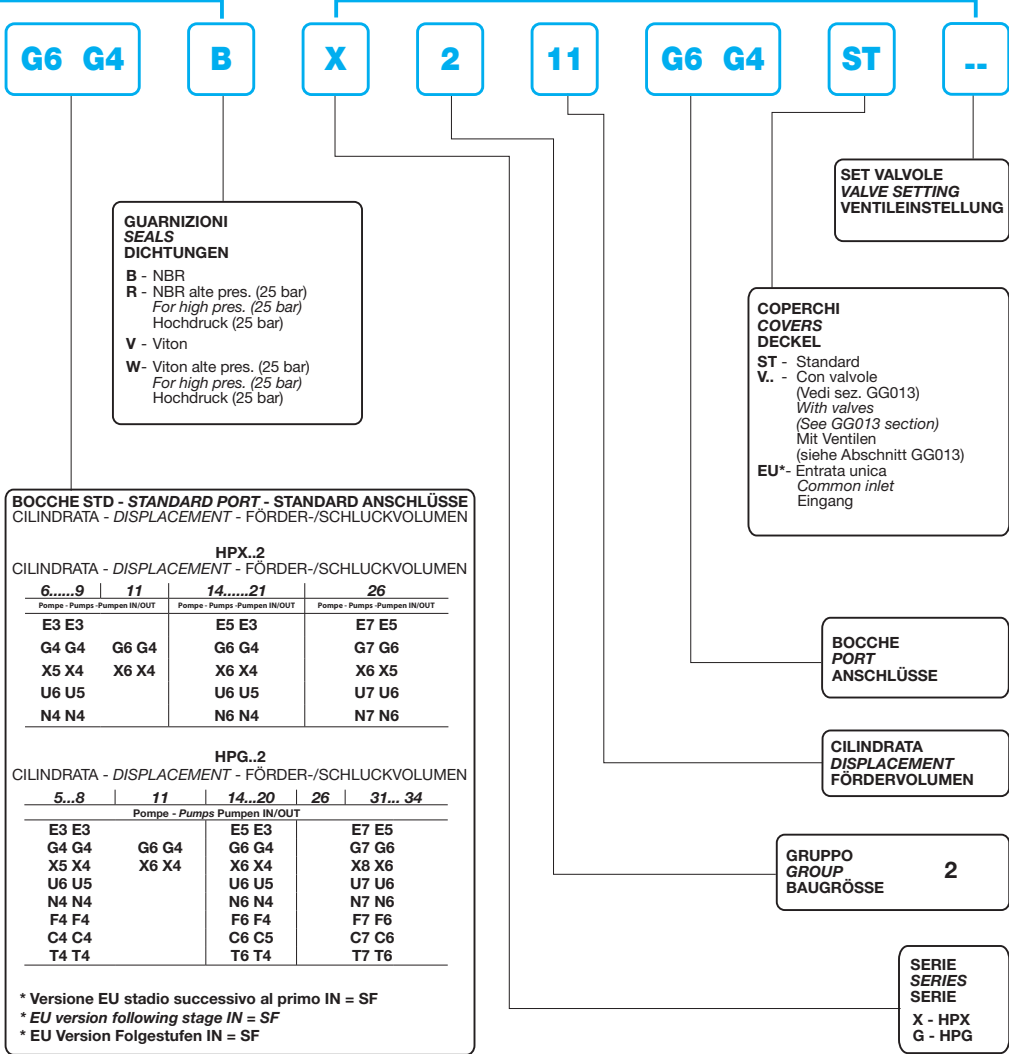

PER OGNI STADIO AGGIUNTO RIPETERE LA DESCRIZIONE      DESCRIPTION TO BE REPEATED FOR EVERY ADDED SECTION      FÜR JEDE STUFE BITTE DIE BESCHREIBUNG WIEDERHOLEN.

---

Questa pagina è intenzionalmente bianca  
*This page is intentionally blank*  
Diese Seite ist bewusst frei gelassen